

VX series

6,000kg / 7,000kg / 8,000kg

Diesel Forklift Trucks



- Intellix Vehicle Management System
- CAN bus technology
- Oil Immersed Brakes
- Yale AccuTouch Mini Levers, PalmTech joystick and manual levers
- Pneumatic, supercushion and Michelin XZM radial tyres

Now with Stage V engines
for lower emissions

VDI 2198 - General Specifications GDP 60VX, GDP 70VX

		GDP 60VX						
		Yale	Yale	Yale	Yale	Yale		
Distinguishing mark	1.1	Manufacturer (abbreviation)		Yale	Yale	Yale	Yale	Yale
	1.2	Manufacturer's type designation				GDP 60VX		
		Engine, Transmission		Kubota 3.8L 55kW Electronic 2 Speed Powershift with Soft Shift Power Reversal	Kubota 3.8L 82kW Electronic 2 Speed Powershift with Soft Shift Power Reversal	Kubota 3.8L 55kW Techtronix 332 3 Speed	Kubota 3.8L 82kW Techtronix 332 3 Speed	Kubota 3.8L 55kW Techtronix 332+ 3 Speed
		Model		Base	Base	Value	Value	Productivity
		Brake Type		Wet Brakes	Wet Brakes	Wet Brakes	Wet Brakes	Wet Brakes
	1.3	Drive: electric (battery or mains), diesel, petrol, LPG		Diesel	Diesel	Diesel	Diesel	Diesel
	1.4	Operator type: hand, pedestrian, standing, seated, orderpicker		Seated	Seated	Seated	Seated	Seated
	1.5	Rated capacity/rated load	Q (t)	6.0	6.0	6.0	6.0	6.0
	1.6	Load centre distance	c (mm)	600	600	600	600	600
1.8	Load distance, centre of drive axle to fork	x (mm)	609	609	609	609	609	
1.9	Wheelbase	y (mm)	2235	2235	2235	2235	2235	
Weights	2.1	Service weight (w/ std equipment: mast, carriage, forks, etc.)	kg	8994	8994	8994	8994	8994
	2.2	Axle loading, laden front/rear	kg	13728 / 1468	13728 / 1468	13728 / 1468	13728 / 1468	13728 / 1468
	2.3	Axle loading, unladen front/rear	kg	4172 / 4822	4172 / 4822	4172 / 4822	4172 / 4822	4172 / 4822
Tyres/chassis	3.1	Tyres: P = pneumatic, V = solid, SE = Superelastic		P	P	P	P	P
	3.2	Tyre size, front		8.25 x 15 14PR	8.25 x 15 14PR	8.25 x 15 14PR	8.25 x 15 14PR	8.25 x 15 14PR
	3.3	Tyre size, rear		8.25 x 15 14PR	8.25 x 15 14PR	8.25 x 15 14PR	8.25 x 15 14PR	8.25 x 15 14PR
	3.5	Number of wheels, front/rear (x = driven wheels)		4X / 2	4X / 2	4X / 2	4X / 2	4X / 2
	3.6	Tread, front	b10 (mm)	1847	1847	1847	1847	1847
	3.7	Tread, rear	b11 (mm)	1536	1536	1536	1536	1536
Dimensions	4.1	Tilt of mast/fork carriage, forward α /backward β	α / β (°)	5 / 10	5 / 10	5 / 10	5 / 10	5 / 10
	4.2	Height, mast lowered	h1 (mm)	2540	2540	2540	2540	2540
	4.3	Free lift▼	h2 (mm)	100	100	100	100	100
	4.4	Lift▼	h3 (mm)	2940	2940	2940	2940	2940
	4.5	Height, mast extended +	h4 (mm)	4040	4040	4040	4040	4040
	4.7	Height of overhead guard (cabin) ○	h6 (mm)	2549	2549	2549	2549	2549
	4.7.1	Cab height (open cab)	mm	2531	2531	2531	2531	2531
	4.8	Seat height/stand height ✕	h7 (mm)	1547	1547	1547	1547	1547
	4.12	Coupling height	h10 (mm)	467	467	467	467	467
	4.19	Overall length	l1 (mm)	4813	4813	4813	4813	4813
	4.20	Length to face of forks	l2 (mm)	3613	3613	3613	3613	3613
	4.21	Overall width	b1/b2 (mm)	2082	2082	2082	2082	2082
	4.22	Fork dimensions	s/e/l	60 / 150 / 1200	60 / 150 / 1200	60 / 150 / 1200	60 / 150 / 1200	60 / 150 / 1200
	4.23	Fork carriage DIN 15173, class/type A/B	(mm)	IVA	IVA	IVA	IVA	IVA
	4.24	Fork carriage width ▶	b3 (mm)	1980	1980	1980	1980	1980
	4.31	Ground clearance, laden, below mast	m1 (mm)	125	125	125	125	125
	4.32	Ground clearance, centre of wheelbase	m2 (mm)	253	253	253	253	253
4.34.1	Aisle width with pallets 1 000 long x 1 200 crossways	Ast (mm)	5129	5129	5129	5129	5129	
4.34.2	Aisle width with pallets 800 wide x 1 200 crossways	Ast (mm)	5329	5329	5329	5329	5329	
4.35	Turning radius (outer)	Wa (mm)	3320	3320	3320	3320	3320	
4.36	Inner turning radius	b13 (mm)	1271	1271	1271	1271	1271	
4.41	90° intersecting aisle (With pallet W = 1200mm, L = 1000mm)	mm	2872	2872	2872	2872	2872	
4.42	Step Height (from ground to running board)	mm	321	321	321	321	321	
4.43	Step Height (between intermediate steps between running board and floor)	mm	256	256	256	256	256	
Performance data	5.1	Travel speed laden/unladen	km/h	20.5 / 21.7	22.7 / 23.9	22.3 / 23.6	24.7 / 26.0	22.3 / 23.6
	5.1.1	Travel speed, laden/unladen, backwards	km/h	20.5 / 21.7	22.7 / 23.9	20.5 / 21.7	20.5 / 21.7	20.5 / 21.7
	5.2	Lift speed, laden/unladen (2LFL)	m/sec	0.45 / 0.47	0.52 / 0.52	0.45 / 0.47	0.52 / 0.52	0.45 / 0.47
	5.3	Lowering speed, laden/unladen (2LFL)	m/sec	0.58 / 0.53	0.58 / 0.53	0.58 / 0.53	0.58 / 0.53	0.58 / 0.53
	5.5	Drawbar pull, laden/unladen @ 1.6 km/h	kN	36.1 / 24.5	46.7 / 24.5	51.2 / 24.5	51.2 / 24.5	51.2 / 24.5
	5.7	Gradeability, laden/unladen @ 1.6 km/h	sec	25% / 29%	33% / 29%	37% / 29%	37% / 29%	37% / 29%
	5.10	Service brake		Hydraulic	Hydraulic	Hydraulic	Hydraulic	Hydraulic
Combustion engine	7.1	Engine manufacturer/type		Kubota V3800 55kW	Kubota V3800 82kW	Kubota V3800 55kW	Kubota V3800 82kW	Kubota V3800 55kW
	7.2	Engine power according to ISO1585	kW	55	82	55	82	55
	7.3	Rated speed at max. power	rpm	2200	2400	2200	2400	2200
	7.3.1	Torque at 1/min	Nm/min-1	308.5 / 1400	373.1 / 1600	308.5 / 1400	373.1 / 1600	308.5 / 1400
	7.4	Number of cylinders/displacement	(-)/cm ³	4 / 3769	4 / 3769	4 / 3769	4 / 3769	4 / 3769
	7.5	Fuel consumption according VDI cycle	l/hr	6.7	7.3	7.0	7.5	7.0
	7.10	Battery voltage/nominal capacity	(V)/(Ah)	12 / 210	12 / 210	12 / 210	12 / 210	12 / 210
Drive Mechanism	8.1	Type of drive unit		Hydrodynamic	Hydrodynamic	Hydrodynamic	Hydrodynamic	Hydrodynamic
	8.2	Manufacturer/Type		DANA	DANA	DANA	DANA	DANA
	8.6	Wheel drive/drive axle manufacturer/type		DANA	DANA	DANA	DANA	DANA
	8.11	Parking Brake		Hand Lever	Hand Lever	Hand Lever	Hand Lever	Hand Lever
Additional data	10.1	Operating pressure for attachments (nominal relief pressure)	bar	155	155	155	155	155
	10.2	Oil volume for attachments (nominal) ◊	l/min	83.3	83.3	83.3	83.3	83.3
	10.3	Hydraulic Tank - capacity (drain & refill)	litres	71.7	71.7	71.7	71.7	71.7
	10.4	Fuel Tank - Capacity	dB(A) L _{PAZ}	74.8	74.8	74.8	74.8	74.8
	10.7	Sound level at driver's ear according DIN 12053 (without / with cab ★	dB(A) L _{WAZ}	77 / 77	79 / 79	77 / 77	79 / 79	77 / 77
	10.7.2	Sound power level during the drive cycle	dB(A) L _{WA}	101	101	101	101	101
	10.7.1	Guaranteed sound power 2001/14/EC		105	105	105	105	105
	10.8	Towing coupling, type DIN		Pin	Pin	Pin	Pin	Pin

★ Measured according to the test cycles and based on the weighting values contained in EN12053

▼ Bottom of forks

✕ Full suspension seat in depressed position

▶ Without load backrest

◊ Add 32mm with load backrest

○ h6 subject to +/- 5mm tolerance

◊ Variable

Spec sheet truck based on :- 3000mm top of forks 2 stage LFL mast with standard 1980mm carriage and 1200mm forks.

All values are nominal values and they are subject to tolerances. For further information, please contact the manufacturer. Yale products might be subject to change without notice.

Yale	Yale	Yale	Yale	Yale	Yale	Yale		1.1
GDP 70VX								1.2
Kubota 3.8L 82kW Techtronix 332+ 3 Speed	Kubota 3.8L 55kW Electronic 2 Speed Powershift with Soft Shift Power Reversal	Kubota 3.8L 82kW Electronic 2 Speed Powershift with Soft Shift Power Reversal	Kubota 3.8L 55kW Techtronix 332 3 Speed	Kubota 3.8L 82kW Techtronix 332 3 Speed	Kubota 3.8L 55kW Techtronix 332+ 3 Speed	Kubota 3.8L 82kW Techtronix 332+ 3 Speed		
Productivity	Base	Base	Value	Value	Productivity	Productivity		
Wet Brakes	Wet Brakes	Wet Brakes	Wet Brakes	Wet Brakes	Wet Brakes	Wet Brakes		
Diesel	Diesel	Diesel	Diesel	Diesel	Diesel	Diesel		1.3
Seated	Seated	Seated	Seated	Seated	Seated	Seated		1.4
6.0	7.0	7.0	7.0	7.0	7.0	7.0	Q (t)	1.5
600	600	600	600	600	600	600	c (mm)	1.6
609	609	609	609	609	609	609	x (mm)	1.8
2235	2235	2235	2235	2235	2235	2235	y (mm)	1.9
8994	10191	10191	10191	9505	9505	9505	kg	2.1
13728 / 1468	14909 / 2282	14909 / 2282	14909 / 2282	14828 / 1677	14828 / 1677	14828 / 1677	kg	2.2
4172 / 4822	4122 / 6069	4122 / 6069	4122 / 6069	4041 / 5464	4041 / 5464	4041 / 5464	kg	2.3
P	P	P	P	P	P	P		3.1
8.25 x 15 14PR	8.25 x 15 14PR	8.25 x 15 14PR	8.25 x 15 14PR	8.25 x 15 14PR	8.25 x 15 14PR	8.25 x 15 14PR		3.2
8.25 x 15 14PR	8.25 x 15 14PR	8.25 x 15 14PR	8.25 x 15 14PR	8.25 x 15 14PR	8.25 x 15 14PR	8.25 x 15 14PR		3.3
4X / 2	4X / 2	4X / 2	4X / 2	4X / 2	4X / 2	4X / 2		3.5
1847	1847	1847	1847	1847	1847	1847	b10 (mm)	3.6
1536	1536	1536	1536	1536	1536	1536	b11 (mm)	3.7
5 / 10	5 / 10	5 / 10	5 / 10	5 / 10	5 / 10	5 / 10	α / β (°)	4.1
2540	2540	2540	2540	2540	2540	2540	h1 (mm)	4.2
100	100	100	100	100	100	100	h2 (mm)	4.3
2940	2940	2940	2940	2940	2940	2940	h3 (mm)	4.4
4040	4040	4040	4040	4040	4040	4040	h4 (mm)	4.5
2549	2549	2549	2549	2549	2549	2549	h6 (mm)	4.7
2531	2531	2531	2531	2531	2531	2531	mm	4.7.1
1547	1547	1547	1547	1547	1547	1547	h7 (mm)	4.8
467	467	467	467	467	467	467	h10 (mm)	4.12
4813	4877	4877	4877	4877	4877	4877	l1 (mm)	4.19
3613	3677	3677	3677	3677	3677	3677	l2 (mm)	4.20
2082	2082	2082	2082	2082	2082	2082	b1/b2 (mm)	4.21
60 / 150 / 1200	60 / 150 / 1200	60 / 150 / 1200	60 / 150 / 1200	60 / 150 / 1200	60 / 150 / 1200	60 / 150 / 1200	s/e/l	4.22
IVA	IVA	IVA	IVA	IVA	IVA	IVA	(mm)	4.23
1980	1980	1980	1980	1980	1980	1980	b3 (mm)	4.24
125	125	125	125	125	125	125	m1 (mm)	4.31
253	253	253	253	253	253	253	m2 (mm)	4.32
5129	5197	5197	5197	5197	5197	5197	Ast (mm)	4.34.1
5329	5397	5397	5397	5397	5397	5397	Ast (mm)	4.34.2
3320	3388	3388	3388	3388	3388	3388	Wa (mm)	4.35
1271	1271	1271	1271	1271	1271	1271	b13 (mm)	4.36
2872	2903	2903	2903	2903	2903	2903	mm	4.41
321	321	321	321	321	321	321	mm	4.42
256	256	256	256	256	256	256	mm	4.43
24.7 / 26.0	20.4 / 21.6	22.6 / 23.8	22.2 / 23.6	24.5 / 26.0	22.2 / 23.6	24.5 / 26.0	km/h	5.1
20.5 / 21.7	23.5 / 25.1	23.5 / 25.1	23.5 / 23.5	20.4 / 21.6	22.6 / 23.8	20.4 / 21.6	km/h	5.1.1
0.52 / 0.52	0.35 / 0.47	0.46 / 0.52	0.35 / 0.47	0.46 / 0.52	0.35 / 0.47	0.46 / 0.52	m/sec	5.2
0.58 / 0.53	0.58 / 0.53	0.58 / 0.53	0.58 / 0.53	0.58 / 0.53	0.58 / 0.53	0.58 / 0.53	m/sec	5.3
51.2 / 24.5	35.9 / 23.8	46.7 / 23.8	51.1 / 23.8	51.2 / 23.8	51.1 / 23.8	51.2 / 23.8	kN	5.5
37% / 29%	23% / 26%	30% / 26%	33% / 26%	33% / 26%	33% / 26%	33% / 26%	sec	5.7
Hydraulic	Hydraulic	Hydraulic	Hydraulic	Hydraulic	Hydraulic	Hydraulic		5.10
Kubota V3800 82kW 82	Kubota V3800 55kW 55	Kubota V3800 82kW 82	Kubota V3800 55kW 55	Kubota V3800 82kW 82	Kubota V3800 55kW 55	Kubota V3800 82kW 82	kW	7.1
2400	2200	2400	2200	2400	2200	2400	rpm	7.2
373.1 / 1600	308.5 / 1400	373.1 / 1600	308.5 / 1400	373.1 / 1600	308.5 / 1400	373.1 / 1600	Nm/min-1	7.3
4 / 3769	4 / 3769	4 / 3769	4 / 3769	4 / 3769	4 / 3769	4 / 3769	(-)/cm ³	7.4
7.5	7.5	8.1	7.8	8.4	7.8	8.4	l/hr	7.5
12 / 210	12 / 210	12 / 210	12 / 210	12 / 210	12 / 210	12 / 210	(V)/(Ah)	7.10
Hydrodynamic	Hydrodynamic	Hydrodynamic	Hydrodynamic	Hydrodynamic	Hydrodynamic	Hydrodynamic		8.1
DANA	DANA	DANA	DANA	DANA	DANA	DANA		8.2
DANA	DANA	DANA	DANA	DANA	DANA	DANA		8.6
Hand Lever	Hand Lever	Hand Lever	Hand Lever	Hand Lever	Hand Lever	Hand Lever		8.11
155	155	155	155	155	155	155	bar	10.1
83.3	83.3	83.3	83.3	83.3	83.3	83.3	l/min	10.2
71.7	71.7	71.7	71.7	71.7	71.7	71.7	litres	10.3
74.8	74.8	74.8	74.8	74.8	74.8	74.8	dB(A) L _{PAZ}	10.4
79 / 79	77 / 77	79 / 79	77 / 77	79 / 79	77 / 77	79 / 79	dB(A) L _{WAZ}	10.7
101	101	101	101	101	101	101	dB(A) L _{WA}	10.7.2
105	105	105	105	105	105	105		10.7.1
Pin	Pin	Pin	Pin	Pin	Pin	Pin		10.8

Distinguishing mark

Weights

Tyres/chassis

Dimensions

Performance data

Combustion engine

Drive Mechanism

Additional data

Lift trucks illustrated may feature optional equipment.

Values may vary with alternative configurations.

VDI 2198 - General Specifications GDP 70SVX, GDP 70SVX9

		GDP 70SVX						
		Yale	Yale	Yale	Yale	Yale		
Distinguishing mark	1.1	Manufacturer (abbreviation)		Yale	Yale	Yale	Yale	Yale
	1.2	Manufacturer's type designation				GDP 70SVX		
		Engine, Transmission		Kubota 3.8L 55kW Electronic 2 Speed Powershift with Soft Shift Power Reversal	Kubota 3.8L 82kW Electronic 2 Speed Powershift with Soft Shift Power Reversal	Kubota 3.8L 55kW Techtronix 332 3 Speed	Kubota 3.8L 82kW Techtronix 332 3 Speed	Kubota 3.8L 55kW Techtronix 332+ 3 Speed
		Model		Base	Base	Value	Value	Productivity
		Brake Type		Wet Brakes	Wet Brakes	Wet Brakes	Wet Brakes	Wet Brakes
	1.3	Drive: electric (battery or mains), diesel, petrol, LPG		Diesel	Diesel	Diesel	Diesel	Diesel
	1.4	Operator type: hand, pedestrian, standing, seated, orderpicker		Seated	Seated	Seated	Seated	Seated
	1.5	Rated capacity/rated load	Q (t)	7.0	6.0	6.0	6.0	6.0
	1.6	Load centre distance	c (mm)	600	600	600	600	600
1.8	Load distance, centre of drive axle to fork	x (mm)	609	609	609	609	609	
1.9	Wheelbase	y (mm)	2235	2235	2235	2235	2235	
Weights	2.1	Service weight (w/std. equipment: mast, carriage, forks, etc.)	kg	10191	10191	10191	10191	10191
	2.2	Axle loading, laden front/rear	kg	14909 / 2282	14909 / 2282	14909 / 2282	14909 / 2282	14909 / 2282
	2.3	Axle loading, unladen front/rear	kg	4122 / 6069	4122 / 6069	4122 / 6069	4122 / 6069	4122 / 6069
Tyres/chassis	3.1	Tyres: P = pneumatic, V = solid, SE = Superelastic		P	P	P	P	P
	3.2	Tyre size, front		8.25x15 14PR	8.25x15 14PR	8.25x15 14PR	8.25x15 14PR	8.25x15 14PR
	3.3	Tyre size, rear		8.25x15 14PR	8.25x15 14PR	8.25x15 14PR	8.25x15 14PR	08.25x15 14PR
	3.5	Number of wheels, front/rear (x = driven wheels)		4X / 2	4X / 2	4X / 2	4X / 2	4X / 2
	3.6	Tread, front	b10 (mm)	1847	1847	1847	1847	1847
	3.7	Tread, rear	b11 (mm)	1536	1536	1536	1536	1536
	Dimensions	4.1	Tilt of mast/fork carriage, forward α /backward β	α / β (°)	5 / 10	5 / 10	5 / 10	5 / 10
4.2		Height, mast lowered	h1 (mm)	2540	2540	2540	2540	2540
4.3		Free lift▼	h2 (mm)	100	100	100	100	100
4.4		Lift▼	h3 (mm)	2940	2940	2940	2940	2940
4.5		Height, mast extended +	h4 (mm)	4040	4040	4040	4040	4040
4.7		Height of overhead guard (cabin) ○	h6 (mm)	2549	2549	2549	2549	2549
4.7.1		Cab height (open cab)	mm	2531	2531	2531	2531	2531
4.8		Seat height/stand height ✕	h7 (mm)	1547	1547	1547	1547	1547
4.12		Coupling height	h10 (mm)	467	467	467	467	467
4.19		Overall length	l1 (mm)	4695	4695	4695	4695	4695
4.20		Length to face of forks	l2 (mm)	3495	3495	3495	3495	3495
4.21		Overall width	b1/b2 (mm)	2082	2082	2082	2082	2082
4.22		Fork dimensions	s/e/l (mm)	60 / 150 / 1200	60 / 150 / 1200	60 / 150 / 1200	60 / 150 / 1200	60 / 150 / 1200
4.23		Fork carriage DIN 15173, class/type A/B	(mm)	IVA	IVA	IVA	IVA	IVA
4.24		Fork carriage width ▶	b3 (mm)	1980	1980	1980	1980	1980
4.31		Ground clearance, laden, below mast	m1 (mm)	125	125	125	125	125
4.32		Ground clearance, centre of wheelbase	m2 (mm)	253	253	253	253	253
4.34.1		Aisle width with pallets 1 000 long x 1 200 crossways	Ast (mm)	4889	4889	4889	4889	4889
4.34.2		Aisle width with pallets 800 wide x 1 200 crossways	Ast (mm)	5089	5089	5089	5089	5089
4.35		Turning radius (outer)	Wa (mm)	3080	3080	3080	3080	3080
4.36	Inner turning radius	b13 (mm)	951	951	951	951	951	
4.41	90° intersecting aisle (With pallet W = 1200mm, L = 1000mm)	mm	2883	2883	2883	2883	2883	
4.42	Step Height (from ground to running board)	mm	321	321	321	321	321	
4.43	Step Height (between intermediate steps between running board and floor)	mm	256	256	256	256	256	
Performance data	5.1	Travel speed laden/unladen	km/h	20.3 / 21.6	22.5 / 23.8	22.1 / 23.5	24.5 / 25.9	22.1 / 23.5
	5.1.1	Travel speed, laden/unladen, backwards	km/h	20.3 / 21.6	22.5 / 23.8	20.3 / 21.6	20.3 / 21.6	20.3 / 21.6
	5.2	Lift speed, laden/unladen (2LFL)	m/sec	0.35 / 0.47	0.46 / 0.52	0.35 / 0.47	0.46 / 0.52	0.35 / 0.47
	5.3	Lowering speed, laden/unladen (2LFL)	m/sec	0.58 / 0.53	0.58 / 0.53	0.58 / 0.53	0.58 / 0.53	0.58 / 0.53
	5.5	Drawbar pull, laden/unladen @ 1.6 km/h	kN	35.8 / 24.3	46.7 / 24.3	51.1 / 24.3	51.2 / 24.3	51.1 / 24.3
	5.7	Gradeability, laden/unladen @ 1.6 km/h	sec	22% / 25%	29% / 25%	32% / 25%	32% / 25%	32% / 25%
	5.10	Service brake		Hydraulic	Hydraulic	Hydraulic	Hydraulic	Hydraulic
Combustion engine	7.1	Engine manufacturer/type		Kubota V3800 55kW	Kubota V3800 82kW	Kubota V3800 55kW	Kubota V3800 82kW	Kubota V3800 55kW
	7.2	Engine power according to ISO1585	kW	55	82	55	82	55
	7.3	Rated speed at max. power	rpm	2200 / 1400	2400 / 1600	2200 / 1400	2400 / 1600	2200 / 1400
	7.3.1	Torque at 1/min	Nm/min-1	308.5 / 1400	373.1 / 1600	308.5 / 1400	373.1 / 1600	308.5 / 1400
	7.4	Number of cylinders/displacement	(-)/cm ³	4/3769	4/3769	4/3769	4/3769	4/3769
	7.5	Fuel consumption according VDI cycle	l/hr	7.9 / 210	8.5 / 210	8.3 / 210	8.8 / 210	8.3 / 210
7.10	Battery voltage/nominal capacity	(V)/(Ah)	12 / 210	12 / 210	12 / 210	12 / 210	12 / 210	
Drive Mechanism	8.1	Type of drive unit		Hydrodynamic	Hydrodynamic	Hydrodynamic	Hydrodynamic	Hydrodynamic
	8.2	Manufacturer/Type		DANA	DANA	DANA	DANA	DANA
	8.6	Wheel drive/drive axle manufacturer/type		DANA	DANA	DANA	DANA	DANA
	8.11	Parking Brake		Hand Lever	Hand Lever	Hand Lever	Hand Lever	Hand Lever
Additional data	10.1	Operating pressure for attachments (nominal relief pressure)	bar	155	155	155	155	155
	10.2	Oil volume for attachments (nominal) ◊	l/min	83.3	83.3	83.3	83.3	83.3
	10.3	Hydraulic Tank - capacity (drain & refill)	litres	71.7	71.7	71.7	71.7	71.7
	10.4	Fuel Tank - Capacity	dB(A) L _{PAZ}	74.8 / 77	74.8 / 79	74.8 / 77	74.8 / 79	74.8 / 77
	10.7	Sound level at driver's ear according DIN 12053 (without / with cab ✕)	dB(A) L _{WAZ}	77 / 77	77 / 77	77 / 77	77 / 77	77 / 77
	10.7.2	Sound power level during the drive cycle	dB(A) L _{WA}	101	101	101	101	101
	10.7.1	Guaranteed sound power 2001/14/EC		105	105	105	105	105
	10.8	Towing coupling, type DIN		Pin	Pin	Pin	Pin	Pin

* Measured according to the test cycles and based on the weighting values contained in EN12053

▼ Bottom of forks

✕ Full suspension seat in depressed position

+ Without load backrest

▶ Add 32mm with load backrest

○ h6 subject to +/- 5mm tolerance

◊ Variable

Spec sheet truck based on :- 3000mm top of forks 2 stage LFL mast with standard 1980mm carriage and 1200mm forks.

All values are nominal values and they are subject to tolerances. For further information, please contact the manufacturer.
Yale products might be subject to change without notice.

Yale	Yale	Yale	Yale	Yale	Yale	Yale		1.1
GDP 70SVX9								1.2
Kubota 3.8L 82kW Techtronix 332+ 3 Speed	Kubota 3.8L 55kW Electronic 2 Speed Powershift with Soft Shift Power Reversal	Kubota 3.8L 82kW Electronic 2 Speed Powershift with Soft Shift Power Reversal	Kubota 3.8L 55kW Techtronix 332 3 Speed	Kubota 3.8L 82kW Techtronix 332 3 Speed	Kubota 3.8L 55kW Techtronix 332+ 3 Speed	Kubota 3.8L 82kW Techtronix 332+ 3 Speed		
Productivity	Base	Base	Value	Value	Productivity	Productivity		
Wet Brakes	Wet Brakes	Wet Brakes	Wet Brakes	Wet Brakes	Wet Brakes	Wet Brakes		
Diesel	Diesel	Diesel	Diesel	Diesel	Diesel	Diesel		1.3
Seated	Seated	Seated	Seated	Seated	Seated	Seated		1.4
6.0	7.0	7.0	7.0	7.0	7.0	7.0	Q (t)	1.5
600	900	900	900	900	900	900	c (mm)	1.6
609	609	609	609	609	609	609	x (mm)	1.8
2235	2235	2235	2235	2235	2235	2235	y (mm)	1.9
10191	11884	11884	11884	11884	11884	11884	kg	2.1
14909 / 2282	16639 / 2337	16639 / 2337	16639 / 2337	16639 / 2337	16639 / 2337	16639 / 2337	kg	2.2
4122 / 6069	4783 / 7101	4783 / 7101	4783 / 7101	4783 / 7101	4783 / 7101	4783 / 7101	kg	2.3
P	P	P	P	P	P	P		3.1
8.25x15 14PR	8.25x1514PR	8.25x15 14PR	8.25x15 14PR	8.25x15 14PR	8.25x15 14PR	8.25x15 14PR		3.2
8.25x15 14PR	8.25x15 14PR	8.25x15 14PR	8.25x15 14PR	8.25x15 14PR	8.25x15 14PR	8.25x15 14PR		3.3
4X / 2	4X / 2	4X / 2	4X / 2	4X / 2	4X / 2	4X / 2		3.5
1847	1847	1847	1847	1847	1847	1847	b10 (mm)	3.6
1536	1536	1536	1536	1536	1536	1536	b11 (mm)	3.7
5 / 10	5 / 9	5 / 9	5 / 9	5 / 9	5 / 9	5 / 9	α / β (°)	4.1
2540	2712	2712	2712	2712	2712	2712	h1 (mm)	4.2
100	0	0	0	0	0	0	h2 (mm)	4.3
2940	3000	3000	3000	3000	3000	3000	h3 (mm)	4.4
4040	4225	4225	4225	4225	4225	4225	h4 (mm)	4.5
2549	2549	2549	2549	2549	2549	2549	h6 (mm)	4.7
2531	2531	2531	2531	2531	2531	2531	mm	4.7.1
1547	1547	1547	1547	1547	1547	1547	h7 (mm)	4.8
467	467	467	467	467	467	467	h10 (mm)	4.12
4695	4770	4770	4770	4770	4770	4770	l1 (mm)	4.19
3495	3570	3570	3570	3570	3570	3570	l2 (mm)	4.20
2082	2082	2082	2082	2082	2082	2082	b1/b2 (mm)	4.21
60 / 150 / 1200	60 / 150 / 1200	60 / 150 / 1200	60 / 150 / 1200	60 / 150 / 1200	60 / 150 / 1200	60 / 150 / 1200	s/e/l	4.22
IVA	IVA	IVA	IVA	IVA	IVA	IVA	(mm)	4.23
1980	1980	1980	1980	1980	1980	1980	b3 (mm)	4.24
125	125	125	125	125	125	125	m1 (mm)	4.31
253	253	253	253	253	253	253	m2 (mm)	4.32
4889	4959	4959	4959	4959	4959	4959	Ast (mm)	4.34.1
5089	5159	5159	5159	5159	5159	5159	Ast (mm)	4.34.2
3080	3145	3145	3145	3145	3145	3145	Wa (mm)	4.35
951	951	951	951	951	951	951	b13 (mm)	4.36
2883	2883	2883	2883	2883	2883	2883	mm	4.41
321	321	321	321	321	321	321	mm	4.42
256	256	256	256	256	256	256	mm	4.43
24.5 / 25.9	20.1 / 21.4	22.3 / 23.7	21.8 / 23.3	24.3 / 25.8	21.8 / 23.3	24.3 / 25.8	km/h	5.1
20.3 / 21.6	20.1 / 21.4	22.3 / 23.7	20.1 / 21.4	20.1 / 21.4	20.1 / 21.4	20.1 / 21.4	km/h	5.1.1
0.46 / 0.52	0.37 / 0.42	0.44 / 0.45	0.37 / 0.42	0.44 / 0.45	0.37 / 0.42	0.44 / 0.45	m/sec	5.2
0.58 / 0.53	0.41 / 0.37	0.41 / 0.37	0.41 / 0.37	0.41 / 0.37	0.41 / 0.37	0.41 / 0.37	m/sec	5.3
51.2 / 24.3	35.4 / 28.1	46.7 / 28.1	50.6 / 28.1	51.2 / 28.1	50.6 / 28.1	51.2 / 28.1	kN	5.5
32% / 25%	19% / 25%	26% / 25%	28% / 25%	29% / 25%	28% / 25%	29% / 25%	sec	5.7
Hydraulic	Hydraulic	Hydraulic	Hydraulic	Hydraulic	Hydraulic	Hydraulic		5.10
Kubota V3800 82kW 82	Kubota V3800 55kW 55	Kubota V3800 82kW 82	Kubota V3800 55kW 55	Kubota V3800 82kW 82	Kubota V3800 55kW 55	Kubota V3800 82kW 82	kW	7.1
2400 / 1600	2200 / 1400	2400 / 1600	2200 / 1400	2400 / 1600	2200 / 1400	2400 / 1600	rpm	7.2
373.1 / 1600	308.5 / 308.5	308.5 / 308.5	308.5 / 308.5	308.5 / 308.5	308.5 / 308.5	308.5 / 308.5	Nm/min-1	7.3
4/3769	4/3769	4/3769	4/3769	4/3769	4/3769	4/3769	(-)/cm ³	7.4
8.8 / 210	9.1 / 210	9.7 / 210	9.5 / 210	10.1 / 210	9.5 / 210	10.1 / 210	l/hr	7.5
12 / 210	12 / 210	12 / 210	12 / 210	12 / 210	12 / 210	12 / 210	(V)/(Ah)	7.10
Hydrodynamic	Hydrodynamic	Hydrodynamic	Hydrodynamic	Hydrodynamic	Hydrodynamic	Hydrodynamic		8.1
DANA	DANA	DANA	DANA	DANA	DANA	DANA		8.2
DANA	DANA	DANA	DANA	DANA	DANA	DANA		8.6
Hand Lever	Hand Lever	Hand Lever	Hand Lever	Hand Lever	Hand Lever	Hand Lever		8.11
155	155	155	155	155	155	155	bar	10.1
83.3	83.3	83.3	83.3	83.3	83.3	83.3	l/min	10.2
71.7	71.7	71.7	71.7	71.7	71.7	71.7	litres	10.3
74.8 / 79	74.8 / 77	74.8 / 79	74.8 / 77	74.8 / 79	74.8 / 77	74.8 / 79	dB(A) L _{PAZ}	10.4
77 / 77	77 / 77	79 / 79	77 / 77	79 / 79	77 / 77	79 / 79	dB(A) L _{WAZ}	10.7
101	101	101	101	101	101	101	dB(A) L _{WA}	10.7.2
105	105	105	105	105	105	105		10.7.1
Pin	Pin	Pin	Pin	Pin	Pin	Pin		10.8

Distinguishing mark

Weights

Tyres/chassis

Dimensions

Performance data

Combustion engine

Drive Mechanism

Additional data

Lift trucks illustrated may feature optional equipment.

Values may vary with alternative configurations.

VDI 2198 - General Specifications GDP 80SVX

			Yale	Yale	Yale	
Distinguishing mark	1.1	Manufacturer (abbreviation)				
	1.2	Manufacturer's type designation			GDP	
		Engine, Transmission		Kubota 3.8L 55kW Electronic 2 Speed Powershift with Soft Shift Power Reversal	Kubota 3.8L 82kW Electronic 2 Speed Powershift with Soft Shift Power Reversal	Kubota 3.8L 55kW Techtronix 332 3 Speed
		Model		Base	Base	Value
		Brake Type		Wet Brakes	Wet Brakes	Wet Brakes
	1.3	Drive: electric (battery or mains), diesel, petrol, LPG		Diesel	Diesel	Diesel
	1.4	Operator type: hand, pedestrian, standing, seated, orderpicker		Seated	Seated	Seated
	1.5	Rated capacity/rated load	Q (t)	8.0	8.0	8.0
	1.6	Load centre distance	c (mm)	600	600	600
1.8	Load distance, centre of drive axle to fork	x (mm)	609	609	609	
1.9	Wheelbase	y (mm)	2235	2235	2235	
Weights	2.1	Service weight (w/ std equipment: mast, carriage, forks, etc.)	kg	11466	11466	11466
	2.2	Axle loading, laden front/rear	kg	16955 / 2511	16955 / 2511	16955 / 2511
	2.3	Axle loading, unladen front/rear	kg	4654 / 6812	4654 / 6812	4654 / 6812
Tyres/chassis	3.1	Tyres: P = pneumatic, V = solid, SE = Superelastic		P	P	P
	3.2	Tyre size, front		8.25 x 15 14PR	8.25 x 15 14PR	8.25x15 14PR
	3.3	Tyre size, rear		8.25 x 15 14PR	8.25 x 15 14PR	8.25x15 14PR
	3.5	Number of wheels, front/rear (x = driven wheels)		4X / 2	4X / 2	4X / 2
	3.6	Tread, front	b10 (mm)	1847	1847	1847
	3.7	Tread, rear	b11 (mm)	1536	1536	1536
	Dimensions	4.1	Tilt of mast/fork carriage, forward α /backward β	α / β (°)	5 / 9	5 / 9
4.2		Height, mast lowered	h1 (mm)	2712	2712	2712
4.3		Free lift▼	h2 (mm)	0	0	0
4.4		Lift▼	h3 (mm)	3000	3000	3000
4.5		Height, mast extended +	h4 (mm)	4225	4225	4225
4.7		Height of overhead guard (cabin) ○	h6 (mm)	2549	2549	2549
4.7.1		Cab height (open cab)	mm	2531	2531	2531
4.8		Seat height/stand height x	h7 (mm)	1547	1547	1547
4.12		Coupling height	h10 (mm)	467	467	467
4.19		Overall length	l1 (mm)	4770	4770	4770
4.20		Length to face of forks	l2 (mm)	3570	3570	3570
4.21		Overall width	b1/b2 (mm)	2082	2082	2082
4.22		Fork dimensions	s/e/l (mm)	60 / 150 / 1200	60 / 150 / 1200	60 / 150 / 1200
4.23		Fork carriage DIN 15173, class/type A/B	b3 (mm)	IVA	IVA	IVA
4.24		Fork carriage width ▽	m1 (mm)	1980	1980	1980
4.31		Ground clearance, laden, below mast	m2 (mm)	125	125	125
4.32		Ground clearance, centre of wheelbase	Ast (mm)	253	253	253
4.34.1		Aisle width with pallets 1 000 long x 1 200 crossways	Ast (mm)	4959	4959	4959
4.34.2		Aisle width with pallets 800 wide x 1 200 crossways	Wa (mm)	5154	5154	5154
4.35		Turning radius (outer)	b13 (mm)	3145	3145	3145
4.36	Inner turning radius	mm	951	951	951	
4.41	90° intersecting aisle (With pallet W = 1200mm, L = 1000mm)	mm	2883	2883	2883	
4.42	Step Height (from ground to running board)	mm	321	321	321	
4.43	Step Height (between intermediate steps between running board and floor)	km/h	256	256	256	
Performance data	5.1	Travel speed laden/unladen	km/h	20.1 / 21.4	22.3 / 23.7	21.8 / 23.3
	5.1.1	Travel speed, laden/unladen, backwards	m/sec	20.1 / 21.4	22.3 / 23.7	20.1 / 21.4
	5.2	Lift speed, laden/unladen (2LFL)	m/sec	0.31 / 0.42	0.43 / 0.45	0.31 / 0.42
	5.3	Lowering speed, laden/unladen (2LFL)	kN	0.41 / 0.37	0.41 / 0.37	0.41 / 0.37
	5.5	Drawbar pull, laden/unladen @ 1.6 km/h	sec	35.4 / 27.4	46.7 / 27.4	50.6 / 27.4
	5.7	Gradeability, laden/unladen @ 1.6 km/h		19% / 25%	25% / 25%	27% / 25%
	5.10	Service brake		Hydraulic	Hydraulic	Hydraulic
Combustion engine	7.1	Engine manufacturer/type	kW	Kubota V3800 55kW	Kubota V3800 82kW	Kubota V3800 55kW
	7.2	Engine power according to ISO1585	rpm	55	82	55
	7.3	Rated speed at max. power	Nm / min-1	2200 / 1400	2400 / 1600	2200 / 1400
	7.3.1	Torque at 1/min	(-) / cm ³	308.5 / 1400	373.1 / 1600	308.5 / 1400
	7.4	Number of cylinders/displacement	l / hr	4/3769	4/3769	4/3769
	7.5	Fuel consumption according VDI cycle	(V) / (Ah)	9.4 / 210	10.0 / 210	9.8 / 210
	7.10	Battery voltage/nominal capacity		12 / 210	12 / 210	12 / 210
Drive Mechanism	8.1	Type of drive unit		Hydrodynamic	Hydrodynamic	Hydrodynamic
	8.2	Manufacturer/Type		DANA	DANA	DANA
	8.6	Wheel drive/drive axle manufacturer/type		DANA	DANA	DANA
	8.11	Parking Brake		Hand Lever	Hand Lever	Hand Lever
Additional data	10.1	Operating pressure for attachments (nominal relief pressure)	bar	155	155	155
	10.2	Oil volume for attachments (nominal) ◇	l / min	83.3	83.3	83.3
	10.3	Hydraulic Tank - capacity (drain & refill)	litres	71.7	71.7	71.7
	10.4	Fuel Tank - Capacity	dB(A) L _{PAZ}	74.8	74.8	74.8
	10.7	Sound level at driver's ear according DIN 12053 (without / with cab ★	dB(A) L _{WAZ}	77 / 77	79 / 79	77 / 77
	10.7.2	Sound power level during the drive cycle	dB(A) L _{WA}	101	101	101
	10.7.1	Guaranteed sound power 2001/14/EC		105	105	105
	10.8	Towing coupling, type DIN		Pin	Pin	Pin

★ Measured according to the test cycles and based on the weighting values contained in EN12053

▼ Bottom of forks

x Full suspension seat in depressed position

+ Without load backrest
 ▸ Add 32mm with load backrest
 ○ h6 subject to +/- 5mm tolerance
 ◇ Variable

Spec sheet truck based on :-
 3000mm top of forks 2 stage LFL mast with standard 1980mm carriage and 1200mm forks.

All values are nominal values and they are subject to tolerances. For further information, please contact the manufacturer.
Yale products might be subject to change without notice.

Yale	Yale	Yale		Manufacturer (abbreviation)	1.1	Distinguishing mark
80SVX				Manufacturer's type designation	1.2	
Kubota 3.8L 82kW Techtronix 332 3 Speed"	Kubota 3.8L 55kW Techtronix 332+ 3 Speed	Kubota 3.8L 82kW Techtronix 332+ 3 Speed		Engine, Transmission		
Value	Productivity	Productivity		Model		
Wet Brakes	Wet Brakes	Wet Brakes		Brake Type		
Diesel	Diesel	Diesel		Drive: electric (battery or mains), diesel, petrol, LPG	1.3	
Seated	Seated	Seated		Operator type: hand, pedestrian, standing, seated, orderpicker	1.4	
8.0	8.0	8.0	Q (t)	Rated capacity/rated load	1.5	
600	600	600	c (mm)	Load centre distance	1.6	
609	609	609	x (mm)	Load distance, centre of drive axle to fork	1.8	
2235	2235	2235	y (mm)	Wheelbase	1.9	
11466	11466	11466	kg	Service weight (w/ std equipment: mast, carriage, forks, etc.)	2.1	
16955 / 2511	16955 / 2511	16955 / 2511	kg	Axle loading, laden front/rear	2.2	
4654 / 6812	4654 / 6812	4654 / 6812	kg	Axle loading, unladen front/rear	2.3	
P	P	P		Tyres: P = pneumatic, V = solid, SE = Superelastic	3.1	
8.25 x 15 14PR	8.25 x 15 14PR	8.25 x 15 14PR		Tyre size, front	3.2	
8.25 x 15 14PR	8.25 x 15 14PR	8.25 x 15 14PR		Tyre size, rear	3.3	
4X / 2	4X / 2	4X / 2		Number of wheels, front/rear (x = driven wheels)	3.5	
1847	1847	1847	b10 (mm)	Tread, front	3.6	
1536	1536	1536	b11 (mm)	Tread, rear	3.7	
5 / 9	5 / 9	5 / 9	α / β (°)	Tilt of mast/fork carriage, forward α /backward β	4.1	
2712	2712	2712	h1 (mm)	Height, mast lowered	4.2	
0	0	0	h2 (mm)	Free lift▼	4.3	
3000	3000	3000	h3 (mm)	Lift▼	4.4	
4225	4225	4225	h4 (mm)	Height, mast extended +	4.5	
2549	2549	2549	h6 (mm)	Height of overhead guard (cabin) ○	4.7	
2531	2531	2531	mm	Cab height (open cab)	4.7.1	
1547	1547	1547	h7 (mm)	Seat height/stand height ✕	4.8	
467	467	467	h10 (mm)	Coupling height	4.12	
4770	4770	4770	l1 (mm)	Overall length	4.19	
3570	3570	3570	l2 (mm)	Length to face of forks	4.20	
2082	2082	2082	b1/b2 (mm)	Overall width	4.21	
60 / 150 / 1200	60 / 150 / 1200	60 / 150 / 1200	s/e/l (mm)	Fork dimensions	4.22	
IVA	IVA	IVA	b3 (mm)	Fork carriage DIN 15173, class/type A/B	4.23	
1980	1980	1980	m1 (mm)	Fork carriage width ▶	4.24	
125	125	125	m2 (mm)	Ground clearance, laden, below mast	4.31	
253	253	253	Ast (mm)	Ground clearance, centre of wheelbase	4.32	
4959	4959	4959	Ast (mm)	Aisle width with pallets 1 000 long x 1 200 crossways	4.34.1	
5154	5154	5154	Wa (mm)	Aisle width with pallets 800 wide x 1 200 crossways	4.34.2	
3145	3145	3145	b13 (mm)	Turning radius (outer)	4.35	
951	951	951	mm	Inner turning radius	4.36	
2883	2883	2883	mm	90° intersecting aisle (With pallet W = 1200mm, L = 1000mm)	4.41	
321	321	321	mm	Step Height (from ground to running board)	4.42	
256	256	256	km/h	Step Height (between intermediate steps between running board and floor)	4.43	
24.3 / 25.8	21.8 / 23.3	24.3 / 25.8	km/h	Travel speed laden/unladen	5.1	
20.1 / 21.4	20.1 / 21.4	20.1 / 21.4	m/sec	Travel speed, laden/unladen, backwards	5.1.1	
0.43 / 0.45	0.31 / 0.42	0.43 / 0.45	m/sec	Lift speed, laden/unladen (2LFL)	5.2	
0.41 / 0.37	0.41 / 0.37	0.41 / 0.37	kN	Lowering speed, laden/unladen (2LFL)	5.3	
51.2 / 27.4	50.6 / 27.4	51.2 / 27.4	sec	Drawbar pull, laden/unladen @ 1.6 km/h	5.5	
28% / 25%	27% / 25%	28% / 25%		Gradeability, laden/unladen @ 1.6 km/h	5.7	
Hydraulic	Hydraulic	Hydraulic		Service brake	5.10	
Kubota V3800 82kW	Kubota V3800 55kW	Kubota V3800 82kW	kW	Engine manufacturer/type	7.1	
82	55	82	rpm	Engine power according to ISO1585	7.2	
2400 / 1600	2200 / 1400	2400 / 1600	Nm/min-1	Rated speed at max. power	7.3	
373.1 / 1600	308.5 / 1400	373.1 / 1600	(-)/cm ³	Torque at 1/min	7.3.1	
4/3769	4/3769	4/3769	l/hr	Number of cylinders/displacement	7.4	
10.4 / 210	9.8 / 210	10.4 / 210	(V)/(Ah)	Fuel consumption according VDI cycle	7.5	
12 / 210	12 / 210	12 / 210		Battery voltage/nominal capacity	7.10	
Hydrodynamic	Hydrodynamic	Hydrodynamic		Type of drive unit	8.1	
DANA	DANA	DANA		Manufacturer/Type	8.2	
DANA	DANA	DANA		Wheel drive/drive axle manufacturer/type	8.6	
Hand Lever	Hand Lever	Hand Lever		Parking Brake	8.1.1	
155	155	155	bar	Operating pressure for attachments (nominal relief pressure)	10.1	
83.3	83.3	83.3	l/min	Oil volume for attachments (nominal) ◊	10.2	
71.7	71.7	71.7	litres	Hydraulic Tank - capacity (drain & refill)	10.3	
74.8	74.8	74.8	dB(A) L _{PAZ}	Fuel Tank - Capacity	10.4	
79 / 79	77 / 77	79 / 79	dB(A) L _{WAZ}	Sound level at driver's ear according DIN 12053 (without / with cab ★	10.7	
101	101	101	dB(A) L _{WA}	Sound power level during the drive cycle	10.7.2	
105	105	105		Guaranteed sound power 2001/14/EC	10.7.1	
Pin	Pin	Pin		Towing coupling, type DIN	10.8	

Lift trucks illustrated may feature optional equipment.

Values may vary with alternative configurations.

Truck Dimensions

$A_{st} = W_a + x + l_6 + a$ (see lines 4.34.1 and 4.34.2).
 a = Minimum operating distance.
 (VDI standard = 200mm BITA recommendation = 300mm).
 l_6 = load length.

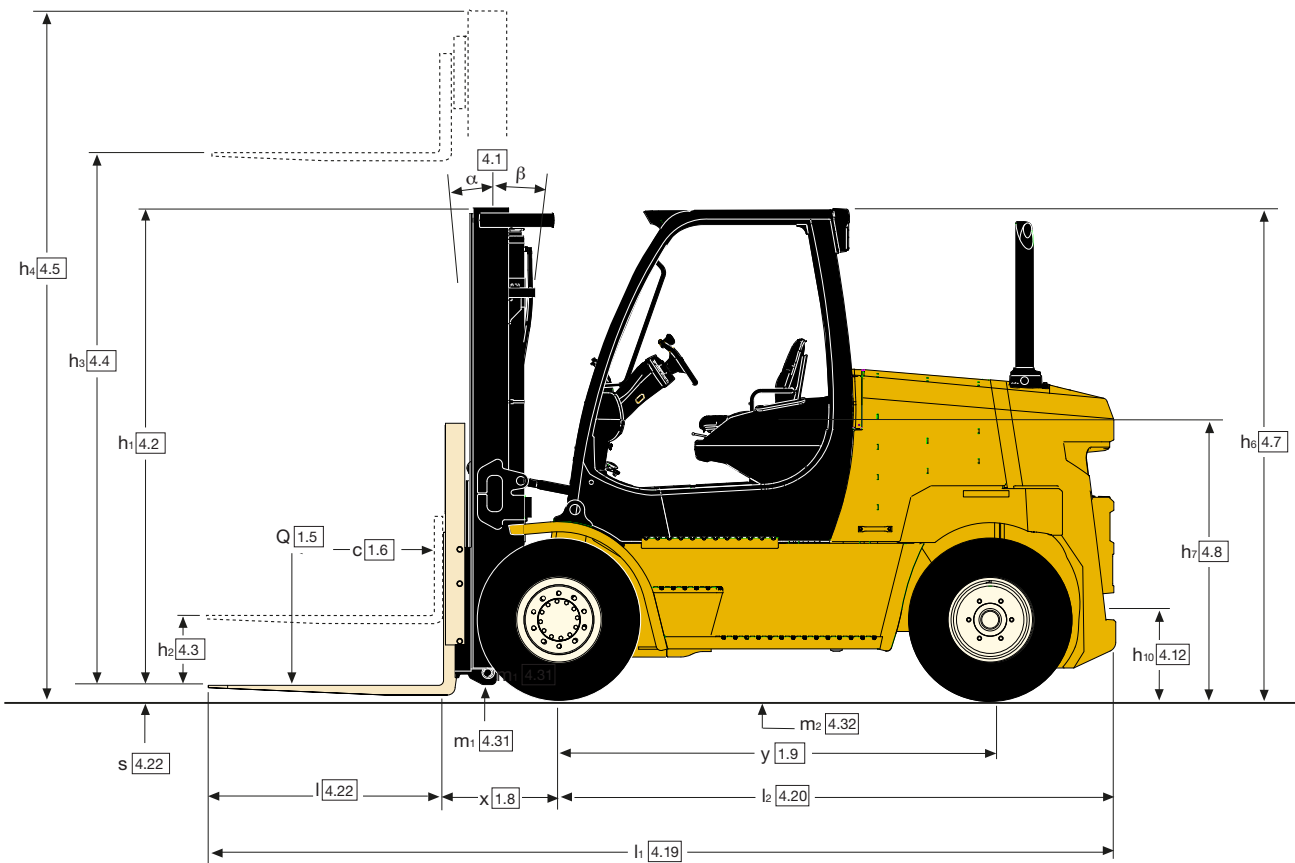
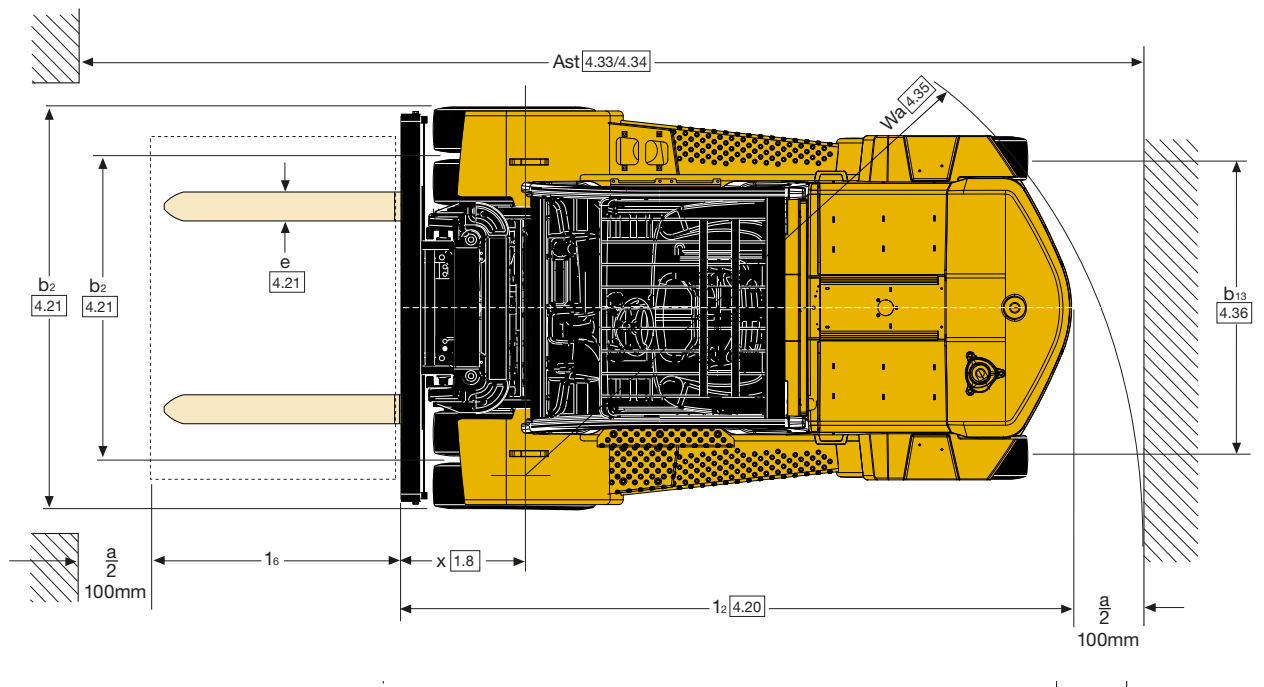

Mast Data - GDP60VX, GDP70VX, GDP70SVX

Mast type	Maximum Fork Height mm (TOF)	Back tilt	Overall Lowered height mm	Overall Extended height mm	Free lift height mm (TOF)
2 Stage LFL	3000	10°	2516	4417	100
	3400	10°	2716	4817	100
	4400	10°	3216	5817	100
	5400	10°	3716	6817	100
	6000	10°	4116	7417	100
3 Stage FFL	4700	6°	2576	6118	1425
	5600	6°	2876	7018	1725
	6200	6°	3126	7618	1975
				With LBR	Without LBR

Mast Data - GDP70SVX9, GDP80SVX

Mast type	Maximum Fork Height mm (TOF)	Back tilt	Overall Lowered height mm	Overall Extended height mm	Free lift height mm (TOF)
2 Stage LFL	3065	9°	2712	4350	0
	3565	9°	2962	4850	0
	4565	9°	3462	5850	0
	5565	9°	3962	6850	0
	6065	9°	4212	7350	0
3 Stage FFL	4615	6°	2702	6077	1565
	5515	6°	3002	6977	1865
	5965	6°	3152	7427	2015
	6565	6°	3355	7847	2111
				With LBR	Without LBR

Capacity Chart - GDP60VX, GDP70VX, GDP70SVX - in kg @ 600mm Load Centre

Mast type	Maximum Fork Height mm (TOF)	8.25x15/14-Ply Dual Pneumatic Drive tyres								
		Without Sideshift			With Integral Sideshift			With Hang-On Sideshift & Fork Positioner		
		60VX	70VX	70SVX	60VX	70VX	70SVX	60VX	70VX	70SVX
2 Stage LFL	3000	6240	7000	7000	5730	6730	7000	5380	6330	6660
	3400	6220	7000	7000	5710	6720	7000	5360	6320	6650
	4400	6170	7000	7000	5670	6670	7000	5320	6270	6600
	5400	6140	7000	7000	5630	6640	6990	5290	6240	6570
	6000	5910	6810	6820	5430	6420	6770	5090	6040	6370
3 Stage LFL	4700	6120	7000	7000	5630	6550	6830	5290	6170	6430
	5600	6010	6900	6910	5520	6440	6720	5190	6060	6330
	6200	5970	6710	6730	5320	6220	6500	4990	5850	6130

Capacity Chart - GDP70SVX9 - in kg @ 900mm Load Centre

Mast type	Maximum Fork Height mm (TOF)	8.25x15/14-Ply Dual Pneumatic Drive tyres	
		Without Sideshift	With Integral Sideshift
		70SVX9	70SVX9
2 Stage LFL	3065	7390	6900
	3565	7380	6890
	4565	7360	6880
	5565	7340	6860
	6065	7260	6780
3 Stage FFL	4615	6880	6430
	5515	6860	6410
	5965	6840	6390
	6565	6610	6170

Capacity Chart - GDP80SVX - in kg @ 600mm Load Centre

Mast type	Maximum Fork Height mm (TOF)	Without Sideshift	With Integral Sideshift & Fork Positioner
		80SVX	80SVX
		2 Stage LFL	3065
3565	8000		7950
4565	8000		7930
5565	8000		7900
6065	7920		7810
3 Stage FFL	4615	8000	7410
	5515	8000	7390
	5965	7970	7360
	6565	7750	7160

All values are nominal values and they are subject to tolerances. For further information, please contact the manufacturer.

Yale products might be subject to change without notice.

Lift trucks illustrated may feature optional equipment.

Values may vary with alternative configurations.

Engine Specifications

Stage V Diesel Engine Specification

Base, Value

Engine	Kubota
Cylinders	Inline 4
Displacement	3.6 litre
Power	62.3kW @ 2,400rpm
Torque	296Nm @ 1,600rpm

Stage V Diesel Engine Specification

Base, Value, Productivity

Engine	Kubota
Cylinders	Inline 4
Displacement	3.8 litre
Power	81.5kW @ 2,400rpm
Torque	373Nm @ 1,600rpm

Rated Load vs. Load Center - Hook Carriage

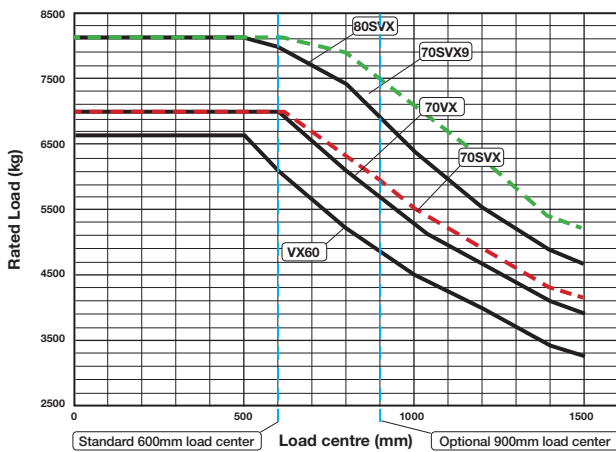

Truck Configuration

2 stage LFL mast at

Model	MFH - Top of Forks (mm)
60VX, 70VX, 70SVX	5400
70SVX9, 80SVX	5565
Carriage	1980mm Standard Hook with Load Backrest
Basic Truck	LPG with 2 speed transmission and Overhead Guard

The ratings are computed using fork lengths as below:

	Load Centre (mm)	Fork Length (mm)
All models	500 to 700	1200
	Over 700 to 1000	1500
	Over 1000 to 1200	1800
	Over 1220	2400

Ratings computed using high strength, 65x200mm forks above the following load centres to reach full truck capacity.

Model	Load Center (mm)
60VX	1400
70VX	600
70SVX	600
70SVX9	1050
80SVX	1400

VX series

Models: GDP 60VX, GDP 70VX, GDP 70SVX, GDP 70SVX9, GDP 80SVX

Yale Veracitor VX Series

Available in three configurations;

Base - top performance with minimised cost of acquisition.

Value - excellent performance, lowest hourly operating cost.

Productivity - maximum performance utilising state-of-the-art features.

Diesel Engines

Kubota turbo charged diesel engines with intercooler and electronically controlled high pressure common rail fuel system regulations.

Base - Kubota 3.8L 55kW engine with Powershift 2 with soft-shift power reversal.

Base - Kubota 3.8L 82kW engine with Powershift 2 with soft-shift power reversal.

Value and Productivity - Kubota 3.8L 55kW engine with Techtronix 332.

Value and Productivity - Kubota 3.8L 82kW engine with Techtronix 332.

Stage V: Stage V fully compliant engines with DPF (Diesel Particulate Filter) reduces emissions and removes diesel smell and soot particles from the exhaust. Stage V engines do not adversely affect the truck performance or productivity and acceleration and lifting/lowering speeds remain unchanged. Unlike some larger emission compliant machines the engine system does not utilise Diesel Emission Fluid (DEF; known as "Adblue")

Two Transmissions

Powershift Electronic - Powershift Electronic transmission has two forward and two reverse speeds, electronic shift control for smooth hydraulic inching, neutral start switch, and anti-restart protection.

Techtronix 332 series - Powershift Electronic plus Auto Deceleration System (ADS), Controlled Power Reversal (CPR). The Techtronix 332 features three speeds forward and two speeds in reverse.

Cooling System

Sealed cooling system with high capacity radiator and integrated transmission oil cooler. Optional combi-cooler radiator has an externally mounted transmission oil cooler.

Drive Axle

Able to withstand heavy duty applications and absorb shock loads with increased resistance to torsion stress, isolated from the transmission by heavy-duty rubber mounting.

Brakes

Standard Oil immersed brakes with low pedal effort. Brakes require no adjustments, little maintenance with a long service life. The system has a sealed master cylinder, instrument panel fluid level sensor and warning light.

Hydraulic Power Steering

Responsive control, eliminating mechanical linkages for reduced surface shock and maintenance. Centred, textured steering wheel has a spinner knob with four turns lock-to-lock. Steer cylinder is located within the the steer axle for protection.

Steer Axle

Cast steel mounted on phenolic bushings for excellent stability and axle articulation.

Chassis

Unitised frame structure with low step height.

Operator's Compartment

Standard cowl mounted hydraulic control levers; all models are available with optional AccuTouch mini-levers with horn and direction switch.

Full Suspension Seat and isolated powertrain provide best in class Whole-Body Vibration levels for operator comfort. Automotive-style pedals with a large, single inch/brake pedal.

Intellix Vehicle System Management (VSM)

Provides extensive monitoring and control of functions and systems. CAN bus wiring, sealed connectors and Hall effect sensors reduces complexity for truck system communication.

Hydraulic System

Incorporates a gear type pump with a cast iron body and protection from overloads via a lift circuit relief valve with a secondary valve for tilt and auxiliary functions. Oil is double filtered. AccuTouch minilevers have an emergency lowering valve to allow lowering in the event of power loss.

Masts

Hi-Vis 2 stage LFL and 3 stage FFL masts afford outstanding visibility. Nested and rolled channels, angled load rollers plus formed cross-members provide high strength. All hoses are routed internally for protection and improved visibility. Standard hook-type carriages handle a wide variety of forks and attachments.

Options

- Powertrain protection system
- Premium monitoring package
- High air intake with precleaner
- Accumulator
- Halogen headlights and rear drive lights
- Traction speed limiter
- Return-to-set tilt
- Integral operator's cab
- Swivel full suspension seats
- Foot Directional Control pedal
- Operator password
- Mirrors
- Alarm - reverse actuated 82-102 dB(A) - self-adjusting
- Amber strobe light - Continuous activated
- Solid and radial tyres
- 4 function (2 aux.) hydraulic control valve
- 5° forward / 6° backward tilt.

VX series

Models: GDP 60VX, GDP 70VX, GDP 70SVX, GDP 70SVX9, GDP 80SVX



Yale Europe Materials Handling
Centennial House, Frimley Business Park,
Frimley, Surrey GU16 7SG
United Kingdom



Tel: +44 (0) 1276 538500
Fax: +44 (0) 1276 538559

www.yale.com

Publication part no. 220990347 Rev.12 Printed in The Netherlands (0320HG) EN.
HYSTER-YALE UK LIMITED trading as Yale Europe Materials Handling.

Safety: This truck conforms to the current EU requirements.

Specification is subject to change without notice.

Yale, VERACITOR and  are registered trademarks. "PEOPLE, PRODUCTS, PRODUCTIVITY",
PREMIER, Hi-Vis, and CSS are trademarks in the United States and certain other jurisdictions.
MATERIALS HANDLING CENTRAL and MATERIAL HANDLING CENTRAL are Service Marks in
the United States and certain other jurisdictions.  is a Registered Copyright.

© Yale Europe Materials Handling 2020. All rights reserved. Truck shown with optional equipment.
Country of Registration: England and Wales. Company Registration Number: 02636775

