

VX series

6,000kg / 7,000kg

Diesel & LPG Forklift Trucks



- Intellix Vehicle Management System
- CAN bus technology
- Oil Immersed Brakes
- Yale AccuTouch Mini Levers, PalmTech joystick and manual levers
- Pneumatic, supercushion and Michelin XZM radial tyres

Truck Dimensions

If $b_{12/2} \leq b_{13}$
 $Ast = Wa + x + l_6 + a$
 $Ast = Wa + R + a = Wa + ((\sqrt{l_6 + x})^2 + (b_{12/2} - b_{13})^2) + a$

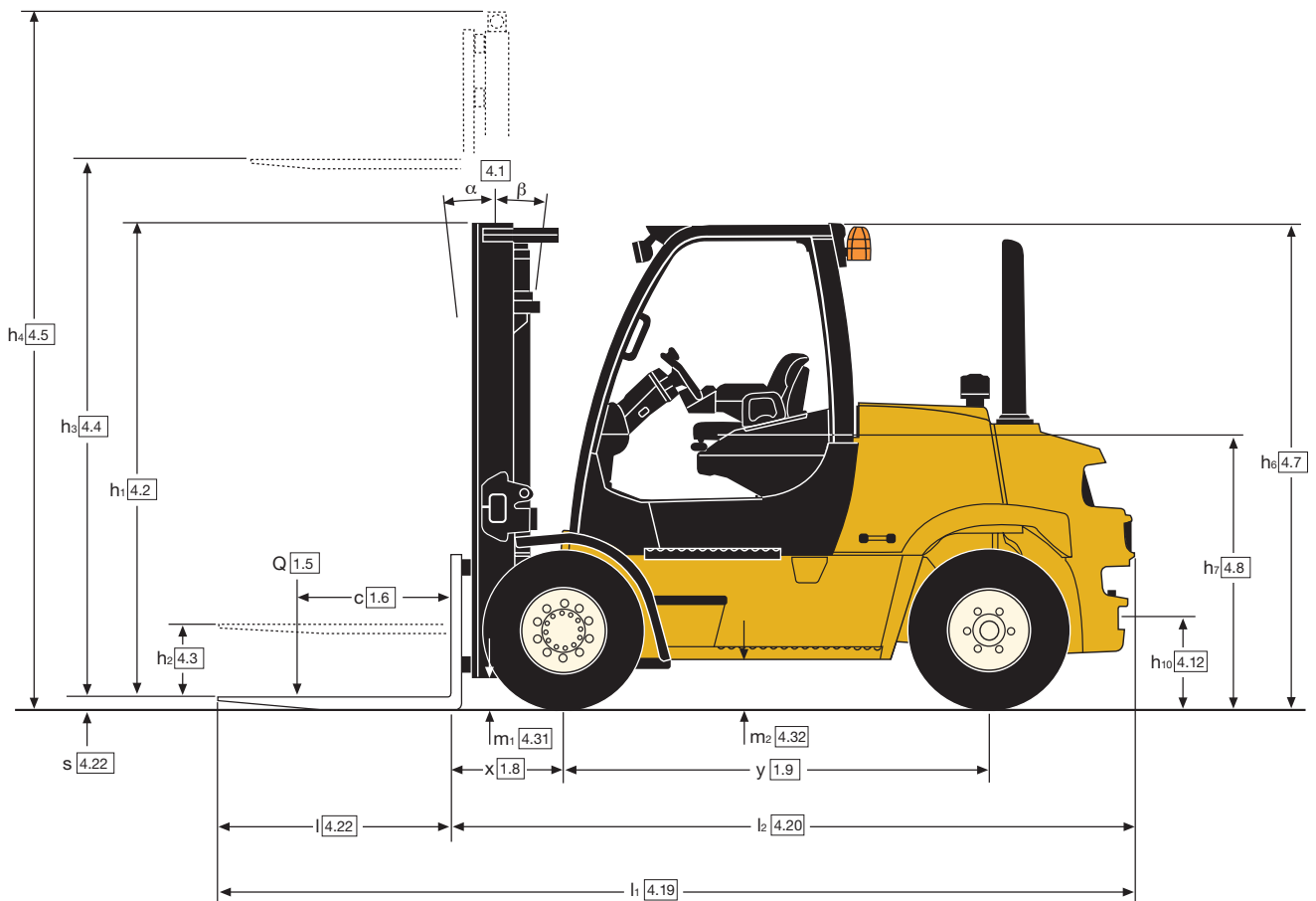
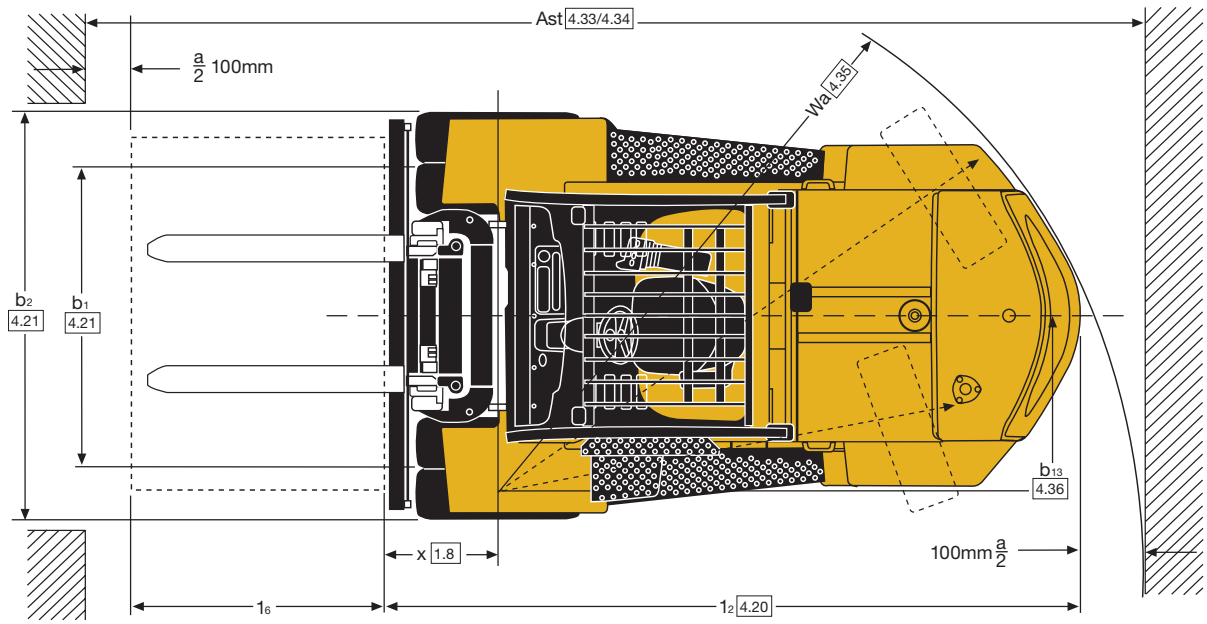

GDP/GLP 60-70VX Dual Drive mast details and capacity ratings (kg) - Pneumatic tyres

Model							GDP/GLP 60-70VX					
Tyre size, front							All tyre types		All tyre types		All tyre types	
Overall width, front							600mm Load Centre (kg)		600mm Load Centre (kg)		600mm Load Centre (kg)	
Mast	h ₁ (mm)	h _{2+s} (mm)	h ₃ (mm)	h ₄ (mm)	Tilt		with carriage		with carriage + sideshift		with carriage + sideshifting fork positioner	
					F	B	GDP/GLP 60VX	GDP/GLP 70VX	GDP/GLP 60VX	GDP/GLP 70VX	GDP/GLP 60VX	GDP/GLP 70VX
2 Stage LFL	2540	160	3000	4354*	-	10°	6000	7000	5760	6710	5690	6630
	2740	160	3400	4754*	-	10°	6000	7000	5750	6700	5680	6620
	3240	160	4400	5754*	-	10°	6000	7000	5700	6650	5630	6570
	3740	160	5400	6754*	-	10°	6000	7000	5670	6620	5600	6540
	4165	160	6000	7354*	-	6°	5810	6800	5480	6410	5410	6340
3 Stage LFL	2570	1440**	4700	6054*	-	6°	6000	7000	5560	6480	5490	6400
	2870	1740**	5600	6954*	-	6°	5910	6900	5450	6360	5380	6290
	3120	1990**	6200	7554*	-	6°	5720	6700	5260	6150	5190	6080

* Measured with LBR, deduct 224mm without LBR.
 ** Measured without LBR, deduct 224mm with LBR.

All values are nominal values and they are subject to tolerances. For further information, please contact the manufacturer.

Values may vary with alternative configurations.

Yale products might be subject to change without notice.
 Lift trucks illustrated may feature optional equipment.

Engine Specifications

Stage IIIB Diesel Engine Specification Base

Engine	Kubota
Cylinders	Inline 4
Displacement	3.8 litre
Power	55kW @ 2,200rpm
Torque	371Nm @ 1,400rpm

Stage IV Diesel Engine Specification Value, Productivity

Engine	Kubota
Cylinders	Inline 4
Displacement	3.8 litre
Power	78kW @ 2,200rpm
Torque	373Nm @ 1,400rpm

LPG Engine Specification Base, Value, Productivity

Engine	PSI
Cylinders	V6
Displacement	4.3 litre
Power	71.6kW @ 2,400rpm
Torque	285Nm @ 2,400rpm

Capacities graph - Standard carriage

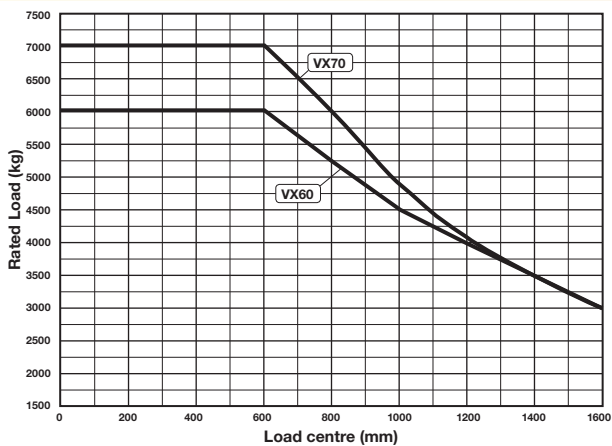

VDI 2198 - General Specifications GDP 60VX, GDP 70VX - Diesel engines

			Yale	Yale	Yale	Yale		
Distinguishing mark	1.1	Manufacturer (abbreviation)						
	1.2	Manufacturer's type designation			GDP 60VX			
		Engine, Transmission		Kubota 3.8L 55kW, Electronic Powershift, 2 Speed with soft Shift Power Reversal	Kubota 3.8L 78kW, Electronic 2 Speed Powershift with Soft Shift Power Reversal	Kubota 3.8L 55kW, Techtronix 300, 3 speed	Kubota 3.8L 78kW, Techtronix 300, 3 speed	Kubota 3.8L 78kW, Techtronix 300, 3 speed
		Model		Base	Base	Value	Value	Productive
		Brake Type		Oil Immersed	Oil Immersed	Oil Immersed	Oil Immersed	Oil Imme
	1.3	Drive: electric (battery or mains), diesel, petrol, LPG		Diesel	Diesel	Diesel	Diesel	Diesel
	1.4	Operator type: hand, pedestrian, standing, seated, orderpicker		Seated Rider	Seated Rider	Seated Rider	Seated Rider	Seated R
	1.5	Rated capacity / rated load	Q (t)	6.0	6.0	6.0	6.0	6.0
	1.6	Load centre distance	c (mm)	600	600	600	600	600
1.8	Load distance, centre of drive axle to fork	x (mm)	601	601	601	601	601	
1.9	Wheelbase	y (mm)	2235	2235	2235	2235	2235	
Weights	2.1	Service weight (with standard equipment: mast, carriage, forks, etc.)	kg	8543	8543	8543	8543	8543
	2.2	Axle loading, laden front/rear	kg	13077 / 1466	13077 / 1466	13077 / 1466	13077 / 1466	13077 / 1466
	2.3	Axle loading, unladen front/rear	kg	3853 / 4690	3853 / 4690	3853 / 4690	3853 / 4690	3853 / 4690
Tyres/chassis	3.1	Tyres: P=pneumatic, C=cushion, SC=supercushion		P	P	P	P	P
	3.2	Tyre size, front		8.25 x 15 14PR	8.25 x 15 14PR	8.25 x 15 14PR	8.25 x 15 14PR	8.25 x 15 14PR
	3.3	Tyre size, rear		8.25 x 15 14PR	8.25 x 15 14PR	8.25 x 15 14PR	8.25 x 15 14PR	8.25 x 15 14PR
	3.5	Number of wheels, front / rear (x = driven wheels)		4x / 2	4x / 2	4x / 2	4x / 2	4x / 2
	3.6	Tread, front	b ₁₀ (mm)	1846	1846	1846	1846	1846
	3.7	Tread, rear	b ₁₁ (mm)	1536	1536	1536	1536	1536
	4.1	Tilt of mast / fork carriage, forward α / backward β	α / β (°)	5 / 10	5 / 10	5 / 10	5 / 10	5 / 10
	4.2	Height, mast lowered	h ₁ (mm)	2540	2540	2540	2540	2540
	4.3	Free lift ▼	h ₂ (mm)	100	100	100	100	100
Dimensions	4.4	Lift ▼	h ₃ (mm)	2940	2940	2940	2940	2940
	4.5	Height, mast extended +	h ₄ (mm)	4195	4195	4195	4195	4195
	4.7	Height of overhead guard (cabin) ○	h ₆ (mm)	2531	2531	2531	2531	2531
	4.7.1	Cab height (open cab)	mm	1540	1540	1540	1540	1540
	4.8	Seat height / stand height ✕	h ₇ (mm)	474	474	474	474	474
	4.12	Coupling height	h ₁₀ (mm)	4805	4805	4805	4805	4805
	4.19	Overall length	l ₁ (mm)	4805	4805	4805	4805	4805
	4.20	Length to face of forks	l ₂ (mm)	3605	3605	3605	3605	3605
	4.21	Overall width	b ₁ /b ₂ (mm)	2082	2082	2082	2082	2082
	4.22	Fork dimensions	s/e/l (mm)	60 / 150 / 1200	60 / 150 / 1200	60 / 150 / 1200	60 / 150 / 1200	60 / 150 / 1200
	4.23	Fork carriage DIN 15173, class/type A/B		IVA	IVA	IVA	IVA	IVA
	4.24	Fork carriage width ▶	b ₃ (mm)	1980	1980	1980	1980	1980
		Fork Spacing -Standard Carriage - Minimum Inside to inside edge	mm	160	160	160	160	160
		Fork Spacing -Standard Carriage - Maximum outside to outside edge	mm	1876	1876	1876	1876	1876
	4.31	Ground clearance, laden, below mast	m ₁ (mm)	125	125	125	125	125
	4.32	Ground clearance, centre of wheelbase	m ₂ (mm)	253	253	253	253	253
	4.34.1	Aisle width with pallets 1,000 long x 1,200 crossways	A _{st} (mm)	5163	5163	5163	5163	5163
	4.34.2	Aisle width with pallets 800 wide x 1,200 crossways	A _{st} (mm)	5329	5329	5329	5329	5329
4.35	Turning radius (outer)	W _a (mm)	3320	3320	3320	3320	3320	
4.36	Inner turning radius	b ₁₃ (mm)	230	230	230	230	230	
4.41	90° intersecting aisle (With pallet W = 1,200mm, L = 1,000mm)	mm	2823	2823	2823	2823	2823	
4.42	Step Height (from ground to running board)	mm	321	321	321	321	321	
4.43	Step Height (between intermediate steps between running board and floor)	mm	256	256	256	256	256	
Performance data	5.1	Travel speed laden / unladen	km/h	19.7 / 21.4	19.7 / 21.4	21.3 / 23.2	21.3 / 23.2	21.3 / 23.2
	5.2	Lift speed, laden / unladen (2LFL)	m/s	0.47 / 0.48	0.47 / 0.48	0.47 / 0.48	0.47 / 0.48	0.47 / 0.48
	5.3	Lowering speed, laden / unladen (2LFL)	m/s	0.58 / 0.53	0.58 / 0.53	0.58 / 0.53	0.58 / 0.53	0.58 / 0.53
	5.5	Drawbar pull, laden / unladen @ 1.6 km/h	kN	35.9 / 24.4	35.9 / 24.4	44.5 / 24.4	48.3 / 24.4	44.5 / 24.4
	5.7	Gradeability, laden / unladen @ 1.6 km/h	%	24 / 31	24 / 31	33 / 31	36 / 31	33 / 31
	5.10	Service brake		Hydraulic	Hydraulic	Hydraulic	Hydraulic	Hydraulic
Combustion engine	7.1	Engine manufacturer / type		Kubota V3800 55kW	Kubota V3800 78kW	Kubota V3800 55kW	Kubota V3800 78kW	Kubota V3800 78kW
	7.2	Engine power according to ISO1585	kW	55	78	55	78	55
	7.3	Rated speed at max. power	rpm	2200	2200	2200	2200	2200
	7.4	Number of cylinders / displacement	cm ³	4 / 3769	4 / 3769	4 / 3769	4 / 3769	4 / 3769
	7.5	Fuel consumption according VDI cycle	l/hr	6.3	6.3	6.6	7.1	6.6
Drive Mechanism	8.1	Type of drive unit		Hydrodynamic	Hydrodynamic	Hydrodynamic	Hydrodynamic	Hydrodynamic
	8.2	Manufacturer / Type		DANA	DANA	DANA	DANA	DANA
	8.6	Wheel drive / drive axle manufacturer/type		DANA	DANA	DANA	DANA	DANA
	8.1.1	Service brake		Hydraulic	Hydraulic	Hydraulic	Hydraulic	Hydraulic
	8.1.2	Parking Brake		Hand Lever	Hand Lever	Hand Lever	Hand Lever	Hand Lever
Additional data	10.1	Operating pressure for attachments (nominal relief pressure)	bar	155	155	155	155	155
	10.2	Oil volume for attachments (nominal) ◇	l/min	83.3	83.3	83.3	83.3	83.3
	10.3	Hydraulic Tank - capacity (drain & refill)	litres	71.7	71.7	71.7	71.7	71.7
	10.4	Fuel Tank - Capacity (Diesel)	litres	74.8	74.8	74.8	74.8	74.8
	10.7	Sound level at driver's ear according DIN 12053 (without / with cab) ★	dB(A) L _{PAZ}	77	77	77	79	77
	10.7.1	Sound power level during the drive cycle	dB(A) L _{WAZ}	101	101	101	101	101
	10.7.2	Guaranteed sound power 2001/14/EC	dB(A) L _{WA}	105	105	105	105	105
	10.8	Towing coupling, type DIN		Pin	Pin	Pin	Pin	Pin

★ Measured according to the test cycles and based on the weighting values contained in EN12053

▼ Bottom of forks
 ✕ Full suspension seat in depressed position
 + Without load backrest

▶ Add 32mm with load backrest
 ○ h₆ subject to +/- 5mm tolerance
 ◇ Variable

Spec sheet truck based on :-
 3000mm top of forks 2 stage LFL mast with standard 1981mm Class IVA carriage and 1200mm forks.

Yale	Yale	Yale	Yale	Yale	Yale	Yale	Yale	1.1
GDP 70VX								1.2
3.8L 55kW, Techtronix 300 (AH), 3 speed	Kubota 3.8L 78kW, Techtronix 300 (AH), 3 speed	Kubota 3.8L 55kW, Electronic Powershift, 2 Speed with soft Shift Power Reversal	Kubota 3.8L 78kW, Electronic Powershift, 2 Speed with soft Shift Power Reversal	Kubota 3.8L 55kW, Techtronix 300, 3 speed	Kubota 3.8L 78kW, Techtronix 300, 3 speed	Kubota 3.8L 55kW, Techtronix 300 (AH), 3 speed	Kubota 3.8L 78kW, Techtronix 300 (AH), 3 speed	
Productivity	Productivity	Base	Base	Value	Value	Productivity	Productivity	
Oil Immersed	Oil Immersed	Oil Immersed	Oil Immersed	Oil Immersed	Oil Immersed	Oil Immersed	Oil Immersed	
Diesel	Diesel	Diesel	Diesel	Diesel	Diesel	Diesel	Diesel	1.3
Seated Rider	Seated Rider	Seated Rider	Seated Rider	Seated Rider	Seated Rider	Seated Rider	Seated Rider	1.4
6.0	7.0	7.0	7.0	7.0	7.0	7.0	7.0	1.5
600	600	600	600	600	600	600	600	1.6
601	601	601	601	601	601	601	601	1.8
2235	2235	2235	2235	2235	2235	2235	2235	1.9
8543	9071	9071	9071	9071	9071	9071	9071	2.1
1466	13077 / 1466	14477 / 1594	14477 / 1594	14477 / 1594	14477 / 1594	14477 / 1594	14477 / 1594	2.2
390	3853 / 4690	3717 / 5354	3717 / 5354	3717 / 5354	3717 / 5354	3717 / 5354	3717 / 5354	2.3
P	P	P	P	P	P	P	P	3.1
8.25 x 15 14PR	8.25 x 15 14PR	8.25 x 15 14PR	8.25 x 15 14PR	8.25 x 15 14PR	8.25 x 15 14PR	8.25 x 15 14PR	8.25 x 15 14PR	3.2
8.25 x 15 14PR	8.25 x 15 14PR	8.25 x 15 14PR	8.25 x 15 14PR	8.25 x 15 14PR	8.25 x 15 14PR	8.25 x 15 14PR	8.25 x 15 14PR	3.3
4x / 2	4x / 2	4x / 2	4x / 2	4x / 2	4x / 2	4x / 2	4x / 2	3.5
1846	1846	1846	1846	1846	1846	1846	1846	3.6
1536	1536	1536	1536	1536	1536	1536	1536	3.7
5 / 10	5 / 10	5 / 10	5 / 10	5 / 10	5 / 10	5 / 10	5 / 10	4.1
2540	2540	2540	2540	2540	2540	2540	2540	4.2
100	100	100	100	100	100	100	100	4.3
2940	2940	2940	2940	2940	2940	2940	2940	4.4
4195	4195	4195	4195	4195	4195	4195	4195	4.5
2531	2531	2531	2531	2531	2531	2531	2531	4.7
1540	1540	1540	1540	1540	1540	1540	1540	4.7.1
474	474	474	474	474	474	474	474	4.8
4805	4805	4805	4805	4805	4805	4805	4805	4.12
4805	4869	4869	4869	4869	4869	4869	4869	4.19
3605	3669	3669	3669	3669	3669	3669	3669	4.20
2082	2082	2082	2082	2082	2082	2082	2082	4.21
60 / 150 / 1200	60 / 150 / 1200	60 / 150 / 1200	60 / 150 / 1200	60 / 150 / 1200	60 / 150 / 1200	60 / 150 / 1200	60 / 150 / 1200	4.22
IVA	IVA	IVA	IVA	IVA	IVA	IVA	IVA	4.23
1980	1980	1980	1980	1980	1980	1980	1980	4.24
160	160	160	160	160	160	160	160	
1876	1876	1876	1876	1876	1876	1876	1876	
125	125	125	125	125	125	125	125	4.31
253	253	253	253	253	253	253	253	4.32
5163	5231	5231	5231	5231	5231	5231	5231	4.33
5329	5397	5397	5397	5397	5397	5397	5397	4.34
3320	3388	3388	3388	3388	3388	3388	3388	4.35
230	230	230	230	230	230	230	230	4.36
2823	2856	2856	2856	2856	2856	2856	2856	4.41
321	321	321	321	321	321	321	321	4.42
256	256	256	256	256	256	256	256	4.43
21.3 / 23.2	19.5 / 21.3	19.5 / 21.3	19.5 / 21.3	21.1 / 23.2	21.1 / 23.2	21.1 / 23.2	21.1 / 23.2	5.1
0.47 / 0.48	0.43 / 0.48	0.43 / 0.48	0.43 / 0.48	0.43 / 0.48	0.44 / 0.48	0.44 / 0.48	0.44 / 0.48	5.2
0.58 / 0.53	0.58 / 0.53	0.58 / 0.53	0.58 / 0.53	0.58 / 0.53	0.58 / 0.53	0.58 / 0.53	0.58 / 0.53	5.3
48.3 / 24.4	35.6 / 25.7	35.6 / 25.7	35.6 / 25.7	44.5 / 25.7	48.0 / 25.7	48.0 / 25.7	48.0 / 25.7	5.5
36 / 31	22 / 30	22 / 30	22 / 30	30 / 30	32 / 30	32 / 30	32 / 30	5.7
Hydraulic	Hydraulic	Hydraulic	Hydraulic	Hydraulic	Hydraulic	Hydraulic	Hydraulic	5.10
3800 55kW	Kubota V3800 78kW	Kubota V3800 55kW	Kubota V3800 78kW	Kubota V3800 55kW	Kubota V3800 78kW	Kubota V3800 55kW	Kubota V3800 78kW	7.1
78	55	78	55	78	55	78	55	7.2
2200	2200	2200	2200	2200	2200	2200	2200	7.3
4 / 3769	4 / 3769	4 / 3769	4 / 3769	4/3769	4/3769	4/3769	4/3769	7.4
7.1	7.4	7.4	7.4	7.7	8.3	8.3	8.3	7.5
Hydrodynamic	Hydrodynamic	Hydrodynamic	Hydrodynamic	Hydrodynamic	Hydrodynamic	Hydrodynamic	Hydrodynamic	8.1
DANA	DANA	DANA	DANA	DANA	DANA	DANA	DANA	8.2
DANA	DANA	DANA	DANA	DANA	DANA	DANA	DANA	8.6
Hydraulic	Hydraulic	Hydraulic	Hydraulic	Hydraulic	Hydraulic	Hydraulic	Hydraulic	8.1
Hand Lever	Hand Lever	Hand Lever	Hand Lever	Hand Lever	Hand Lever	Hand Lever	Hand Lever	8.1
155	155	155	155	155	155	155	155	10.1
83.3	83.3	83.3	83.3	83.3	83.3	83.3	83.3	10.2
71.7	71.7	71.7	71.7	71.7	71.7	71.7	71.7	10.3
74.8	74.8	74.8	74.8	74.8	74.8	74.8	74.8	10.4
79	77	77	77	77	79	79	79	10.7
101	101	101	101	101	101	101	101	10.7.2
105	105	105	105	105	105	105	105	10.7.1
Pin	Pin	Pin	Pin	Pin	Pin	Pin	Pin	10.8

Distinguishing mark

Weights

Tyres/chassis

Dimensions

Performance data

Combustion engine

Drive Mechanism

Additional data

All values are nominal values and they are subject to tolerances. For further information, please contact the manufacturer.

Yale products might be subject to change without notice. Lift trucks illustrated may feature optional equipment.

Values may vary with alternative configurations.

VDI 2198 - General Specifications GLP 60VX, GLP 70VX - LPG engines

			Yale	Yale	Yale	Yale	
Distinguishing mark	1.1	Manufacturer (abbreviation)					
	1.2	Manufacturer's type designation		GLP 60VX			
		Engine, Transmission		PSI 4.3L, Electronic 2 Speed Powershift	PSI 4.3L, Electronic 2 Speed Powershift with Soft Shift Power Reversal	PSI 4.3L, Techtronix 300, 3 Speed	PSI 4.3L, Techtronix 300, 3 Speed
		Model		Base	Base	Value	Productivity
		Brake Type		Oil Immersed	Oil Immersed	Oil Immersed	Oil Immersed
	1.3	Drive: electric (battery or mains), diesel, petrol, LPG		LPG	LPG	LPG	LPG
	1.4	Operator type: hand, pedestrian, standing, seated, orderpicker		Seated Rider	Seated Rider	Seated Rider	Seated Rider
	1.5	Rated capacity / rated load	Q (t)	6.0	6.0	6.0	6.0
	1.6	Load centre distance	c (mm)	600	600	600	600
1.8	Load distance, centre of drive axle to fork	x (mm)	601	601	601	601	
1.9	Wheelbase	y (mm)	2235	2235	2235	2235	
Weights	2.1	Service weight (with standard equipment: mast, carriage, forks, etc.)	kg	8493	8493	8493	8493
	2.2	Axle loading, laden front/rear	kg	13052 / 1441	13052 / 1441	13052 / 1441	13052 / 1441
	2.3	Axle loading, unladen front/rear	kg	3828 / 4665	3828 / 4665	3828 / 4665	3828 / 4665
Tyres/chassis	3.1	Tyres: P=pneumatic, C=cushion, SC=supercushion		P	P	P	P
	3.2	Tyre size, front		8.25 x 15 14PR	8.25 x 15 14PR	8.25 x 15 14PR	8.25 x 15 14PR
	3.3	Tyre size, rear		8.25 x 15 14PR	8.25 x 15 14PR	8.25 x 15 14PR	8.25 x 15 14PR
	3.5	Number of wheels, front / rear (x = driven wheels)		4x / 2	4x / 2	4x / 2	4x / 2
	3.6	Tread, front	b ₁₀ (mm)	1846	1846	1846	1846
	3.7	Tread, rear	b ₁₁ (mm)	1536	1536	1536	1536
	4.1	Tilt of mast / fork carriage, forward α / backward β	α / β (°)	5 / 10	5 / 10	5 / 10	5 / 10
	4.2	Height, mast lowered	h ₁ (mm)	2540	2540	2540	2540
	4.3	Free lift ▼	h ₂ (mm)	100	100	100	100
Dimensions	4.4	Lift ▼	h ₃ (mm)	2940	2940	2940	2940
	4.5	Height, mast extended +	h ₄ (mm)	4195	4195	4195	4195
	4.7	Height of overhead guard (cabin) ○	h ₆ (mm)	2531	2531	2531	2531
	4.7.1	Cab height (open cab)	mm	1540	1540	1540	1540
	4.8	Seat height / stand height ✕	h ₇ (mm)	474	474	474	474
	4.12	Coupling height	h ₁₀ (mm)	4805	4805	4805	4805
	4.19	Overall length	l ₁ (mm)	4805	4805	4805	4805
	4.20	Length to face of forks	l ₂ (mm)	3605	3605	3605	3605
	4.21	Overall width	b ₁ /b ₂ (mm)	2082	2082	2082	2082
	4.22	Fork dimensions	s/e/l (mm)	60 / 150 / 1200	60 / 150 / 1200	60 / 150 / 1200	60 / 150 / 1200
	4.23	Fork carriage DIN 15173, class/type A/B		IVA	IVA	IVA	IVA
	4.24	Fork carriage width ▶	b ₃ (mm)	1980	1980	1980	1980
		Fork Spacing -Standard Carriage - Minimum Inside to inside edge	mm	160	160	160	160
		Fork Spacing -Standard Carriage - Maximum outside to outside edge	mm	1876	1876	1876	1876
	4.31	Ground clearance, laden, below mast	m ₁ (mm)	125	125	125	125
	4.32	Ground clearance, centre of wheelbase	m ₂ (mm)	253	253	253	253
	4.34.1	Aisle width with pallets 1,000 long x 1,200 crossways	A _{st} (mm)	5163	5163	5163	5163
	4.34.2	Aisle width with pallets 800 wide x 1,200 crossways	A _{st} (mm)	5329	5329	5329	5329
4.35	Turning radius (outer)	W _a (mm)	3320	3320	3320	3320	
4.36	Inner turning radius	b ₁₃ (mm)	230	230	230	230	
4.41	90° intersecting aisle (With pallet W = 1,200mm, L = 1,000mm)	mm	2823	2823	2823	2823	
4.42	Step Height (from ground to running board)	mm	321	321	321	321	
4.43	Step Height (between intermediate steps between running board and floor)	mm	256	256	256	256	
Performance data	5.1	Travel speed laden / unladen	km/h	21.3 / 23.0	21.3 / 23.0	23.6 / 25.7	23.6 / 25.7
	5.2	Lift speed, laden / unladen (2LFL)	m/s	0.51 / 0.52	0.51 / 0.52	0.51 / 0.52	0.51 / 0.52
	5.3	Lowering speed, laden / unladen (2LFL)	m/s	0.58 / 0.53	0.58 / 0.53	0.58 / 0.53	0.58 / 0.53
	5.5	Drawbar pull, laden / unladen @ 1.6 km/h	kN	33.4 / 24.4	33.4 / 24.4	44.5 / 24.4	44.5 / 24.4
	5.7	Gradeability, laden / unladen @ 1.6 km/h	%	24 / 31	24 / 31	33 / 31	33 / 31
	5.10	Service brake		Hydraulic	Hydraulic	Hydraulic	Hydraulic
Combustion engine	7.1	Engine manufacturer / type		PSI 4.3L	PSI 4.3L	PSI 4.3L	PSI 4.3L
	7.2	Engine power according to ISO1585	kW	71.6	71.6	71.6	71.6
	7.3	Rated speed at max. power	rpm	2400	2400	2400	2400
	7.4	Number of cylinders / displacement	cm³	6 / 4302	6 / 4302	6 / 4302	6 / 4302
	7.5	Fuel consumption according VDI cycle	l/hr	6.2	6.2	6.5	6.5
Drive Mechanism	8.1	Type of drive unit		Hydrodynamic	Hydrodynamic	Hydrodynamic	Hydrodynamic
	8.2	Manufacturer / Type		DANA	DANA	DANA	DANA
	8.6	Wheel drive / drive axle manufacturer/type		DANA	DANA	DANA	DANA
	8.1.1	Service brake		Hydraulic	Hydraulic	Hydraulic	Hydraulic
	8.1.2	Parking Brake		Hand Lever	Hand Lever	Hand Lever	Hand Lever
Additional data	10.1	Operating pressure for attachments (nominal relief pressure)	bar	155	155	155	155
	10.2	Oil volume for attachments (nominal) ◇	l/min	83.3	83.3	83.3	83.3
	10.3	Hydraulic Tank - capacity (drain & refill)	litres	71.7	71.7	71.7	71.7
	10.4	Fuel Tank - Capacity (Diesel)	litres	0	0	0	0
	10.7	Sound level at driver's ear according DIN 12053 (without / with cab) ★	dB(A) L _{PAZ}	82	82	82	82
	10.7.1	Sound power level during the drive cycle	dB(A) L _{WAZ}	103	103	103	103
	10.7.2	Guaranteed sound power 2001/14/EC	dB(A) L _{WA}	107	107	107	107
	10.8	Towing coupling, type DIN		Pin	Pin	Pin	Pin

★ Measured according to the test cycles and based on the weighting values contained in EN12053

▼ Bottom of forks

✕ Full suspension seat in depressed position

⊕ Without load backrest

▶ Add 32mm with load backrest

○ h₆ subject to +/- 5mm tolerance

◇ Variable

Spec sheet truck based on :-
3000mm top of forks 2 stage LFL mast with standard 1981mm Class IVA carriage and 1200mm forks.

Yale	Yale	Yale	Yale		Manufacturer (abbreviation)	1.1	Distinguishing mark
	GLP 70VX				Manufacturer's type designation	1.2	
PSI 4.3L, Electronic 2 Speed Powershift	PSI 4.3L, Electronic 2 Speed Powershift with Soft Shift Power Reversal	PSI 4.3L, Techtronix 300, 3 Speed	PSI 4.3L, Techtronix 300 , 3 Speed		Engine, Transmission		
Base	Base	Value	Productivity		Model		
Oil Immersed LPG	Oil Immersed LPG	Oil Immersed LPG	Oil Immersed LPG		Brake Type		
Seated Rider	Seated Rider	Seated Rider	Seated Rider		Drive: electric (battery or mains), diesel, petrol, LPG	1.3	
7.0	7.0	7.0	7.0	Q (t)	Operator type: hand, pedestrian, standing, seated, orderpicker	1.4	
600	600	600	600	c (mm)	Rated capacity / rated load	1.5	
601	601	601	601	x (mm)	Load centre distance	1.6	
2235	2235	2235	2235	y (mm)	Load distance, centre of drive axle to fork	1.8	
9021	9021	9021	9021	kg	Wheelbase	1.9	
14452 / 1569	14452 / 1569	14452 / 1569	14452 / 1569	kg	Service weight (with standard equipment: mast, carriage, forks, etc.)	2.1	
3692 / 5329	3692 / 5329	3692 / 5329	3692 / 5329	kg	Axle loading, laden front/rear	2.2	
P	P	P	P		Axle loading, unladen front/rear	2.3	
8.25 x 15 14PR	8.25 x 15 14PR	8.25 x 15 14PR	8.25 x 15 14PR		Tyres: P=pneumatic, C=cushion, SC=supercushion	3.1	
8.25 x 15 14PR	8.25 x 15 14PR	8.25 x 15 14PR	8.25 x 15 14PR		Tyre size, front	3.2	
4x / 2	4x / 2	4x / 2	4x / 2		Tyre size, rear	3.3	
1846	1846	1846	1846	b ₁₀ (mm)	Number of wheels, front / rear (x = driven wheels)	3.5	
1536	1536	1536	1536	b ₁₁ (mm)	Tread, front	3.6	
5 / 10	5 / 10	5 / 10	5 / 10	α / β (°)	Tread, rear	3.7	
2540	2540	2540	2540	h ₁ (mm)	Tilt of mast / fork carriage, forward α / backward β	4.1	
100	100	100	100	h ₂ (mm)	Height, mast lowered	4.2	
2940	2940	2940	2940	h ₃ (mm)	Free lift ▼	4.3	
4195	4195	4195	4195	h ₄ (mm)	Lift ▼	4.4	
2531	2531	2531	2531	h ₆ (mm)	Height, mast extended +	4.5	
1540	1540	1540	1540	mm	Height of overhead guard (cabin) ○	4.7	
474	474	474	474	mm	Cab height (open cab)	4.7.1	
4805	4805	4805	4805	h ₇ (mm)	Seat height / stand height ✕	4.8	
4869	4869	4869	4869	h ₁₀ (mm)	Coupling height	4.12	
3669	3669	3669	3669	l ₁ (mm)	Overall length	4.19	
2082	2082	2082	2082	l ₂ (mm)	Length to face of forks	4.20	
60 / 150 / 1200	60 / 150 / 1200	60 / 150 / 1200	60 / 150 / 1200	b ₁ /b ₂ (mm)	Overall width	4.21	
IVA	IVA	IVA	IVA	s/e/l (mm)	Fork dimensions	4.22	
1980	1980	1980	1980		Fork carriage DIN 15173, class/type A/B	4.23	
160	160	160	160	b ₃ (mm)	Fork carriage width ▶	4.24	
1876	1876	1876	1876	mm	Fork Spacing -Standard Carriage - Minimum inside to inside edge		
125	125	125	125	mm	Fork Spacing -Standard Carriage - Maximum outside to outside edge		
253	253	253	253	m ₁ (mm)	Ground clearance, laden, below mast	4.31	
5231	5231	5231	5231	m ₂ (mm)	Ground clearance, centre of wheelbase	4.32	
5397	5397	5397	5397	A _{st} (mm)	Aisle width with pallets 1,000 long x 1,200 crossways	4.33	
3388	3388	3388	3388	A _{st} (mm)	Aisle width with pallets 800 wide x 1,200 crossways	4.34	
230	230	230	230	W _a (mm)	Turning radius (outer)	4.35	
2856	2856	2856	2856	b ₁₃ (mm)	Inner turning radius	4.36	
321	321	321	321	mm	90° intersecting aisle (With pallet W = 1,200mm, L = 1,000mm)	4.41	
256	256	256	256	mm	Step Height (from ground to running board)	4.42	
21.2 / 23.0	21.2 / 23.0	23.5 / 25.6	23.5 / 25.6	mm	Step Height (between intermediate steps between running board & floor)	4.43	
0.48 / 0.52	0.48 / 0.52	0.48 / 0.52	0.48 / 0.52	km/h	Travel speed laden / unladen	5.1	
0.58 / 0.53	0.58 / 0.53	0.58 / 0.53	0.58 / 0.53	m/s	Lift speed, laden / unladen (2LFL)	5.2	
33.1 / 25.7	33.1 / 25.7	44.5 / 25.7	44.5 / 25.7	m/s	Lowering speed, laden / unladen (2LFL)	5.3	
22 / 30	22 / 30	30 / 30	30 / 30	kN	Drawbar pull, laden / unladen @ 1.6 km/h	5.5	
Hydraulic	Hydraulic	Hydraulic	Hydraulic	%	Gradeability, laden / unladen @ 1.6 km/h	5.7	
PSI 4.3L	PSI 4.3L	PSI 4.3L	PSI 4.3L		Service brake	5.10	
71.6	71.6	71.6	71.6		Engine manufacturer / type	7.1	
2400	2400	2400	2400	kW	Engine power according to ISO1585	7.2	
6 / 4302	6 / 4302	6 / 4302	6 / 4302	rpm	Rated speed at max. power	7.3	
7.4	7.4	7.7	7.7	cm ³	Number of cylinders / displacement	7.4	
Hydrodynamic	Hydrodynamic	Hydrodynamic	Hydrodynamic	l/hr	Fuel consumption according VDI cycle	7.5	
DANA	DANA	DANA	DANA		Type of drive unit	8.1	
DANA	DANA	DANA	DANA		Manufacturer / Type	8.2	
Hydraulic	Hydraulic	Hydraulic	Hydraulic		Wheel drive / drive axle manufacturer/type	8.6	
Hand Lever	Hand Lever	Hand Lever	Hand Lever		Service brake	8.1	
155	155	155	155		Parking Brake	8.1	
83.3	83.3	83.3	83.3	bar	Operating pressure for attachments (nominal relief pressure)	10.1	
71.7	71.7	71.7	71.7	l/min	Oil volume for attachments (nominal) ◇	10.2	
0	0	0	0	litres	Hydraulic Tank - capacity (drain & refill)	10.3	
82	82	82	82	litres	Fuel Tank - Capacity (Diesel)	10.4	
103	103	103	103	dB(A) L _{PAZ}	Sound level at driver's ear according DIN 12053 (without / with cab) ★	10.7	
107	107	107	107	dB(A) L _{WAZ}	Sound power level during the drive cycle	10.7.2	
Pin	Pin	Pin	Pin	dB(A) L _{WA}	Guaranteed sound power 2001/14/EC	10.7.1	
					Towing coupling, type DIN	10.8	

All values are nominal values and they are subject to tolerances. For further information, please contact the manufacturer.

Yale products might be subject to change without notice. Lift trucks illustrated may feature optional equipment.

Values may vary with alternative configurations.

VX series

Models: GDP/GLP 60VX, GDP/GLP 70VX



Yale Veracitor VX Series

Available in three configurations;

Base - top performance with minimised cost of acquisition.

Value - excellent performance, lowest hourly operating cost.

Productivity - maximum performance utilising state-of-the-art features.

LPG Engines

The PSI 4.3L engine features a rigid cast iron block, four bearing crankshaft and cast iron camshaft with hydraulic lifters.

Fuel System

The LPG engine uses sequential port fuel injection, the ECU regulates fuel, air and spark advance to provide the necessary torque.

Diesel Engines

Kubota turbo charged diesel engines with intercooler and electronically controlled high pressure common rail fuel system regulations.

Base - Kubota V3800 E4 3.8L (55kW)

Value and Productivity - Kubota V3800 E4 3.8L (78kW), coupled with the Techtronix 300 3-speed transmission.

Stage IV = High productivity and low emissions.

Note: A Stage IIIB engine must run on Ultra Low Sulphur Diesel (ULSD) fuel, with a maximum of 15 ppm sulphur content. Diesel fuel with a higher sulphur content than 15ppm will compromise the emissions performance of the Stage IIIB engine and may result in damage to components.

Two Transmissions

Powershift Electronic - Powershift

Electronic transmission has two forward and two reverse speeds, electronic shift control for smooth hydraulic inching, neutral start switch, and anti-restart protection.

Techtronix 300 series - Powershift

Electronic plus Auto Deceleration System (ADS), Controlled Power Reversal (CPR). The Techtronix 300 features three speeds forward and two speeds in reverse.

Cooling System

Sealed cooling system with high capacity radiator and integrated transmission oil

cooler. Optional combi-cooler radiator has an externally mounted transmission oil cooler.

Drive Axle

Able to withstand heavy duty applications and absorb shock loads with increased resistance to torsion stress, isolated from the transmission by heavy-duty rubber mounting.

Brakes

Standard Oil immersed brakes with low pedal effort. Brakes require no adjustments, little maintenance with a long service life. The system has a sealed master cylinder, instrument panel fluid level sensor and warning light.

Hydraulic Power Steering

Responsive control, eliminating mechanical linkages for reduced surface shock and maintenance. Centred, textured steering wheel has a spinner knob with four turns lock-to-lock. Steer cylinder is located within the the steer axle for protection.

Steer Axle

Cast steel mounted on phenolic bushings for excellent stability and axle articulation.

Chassis

Unitised frame structure with low step height.

Operator's Compartment

Standard cowl mounted hydraulic control levers; all models are available with optional AccuTouch mini-levers with horn and direction switch.

Full Suspension Seat and isolated powertrain provide best in class Whole-Body Vibration levels for operator comfort. Automotive-style pedals with a large, single inch/brake pedal.

Intellix Vehicle System Management (VSM)

Provides extensive monitoring and control of functions and systems. CAN bus wiring, sealed connectors and Hall effect sensors reduces complexity for truck system communication.

Hydraulic System

Incorporates a gear type pump with a cast iron body and protection from overloads via a lift circuit relief valve with a secondary valve for tilt and auxiliary functions. Oil is double filtered. AccuTouch minilevers have an emergency lowering valve to allow lowering in the event of power loss.

Masts

Hi-Vis 2 stage LFL and 3 stage FFL masts afford outstanding visibility. Nested and rolled channels, angled load rollers plus formed cross-members provide high strength. All hoses are routed internally for protection and improved visibility. Standard hook-type carriages handle a wide variety of forks and attachments.

Options

- Powertrain protection system
- Premium monitoring package
- High air intake with precleaner
- Accumulator
- Halogen headlights and rear drive lights
- Traction speed limiter
- Dual LPG tank bracket
- Return-to-set tilt
- Integral operator's cab
- Swivel full suspension seats
- Foot Directional Control pedal
- Operator password
- Mirrors
- Alarm - reverse actuated 82-102 dB(A) - self-adjusting
- Amber strobe light - Continuous activated
- Solid and radial tires
- 4 function (2 aux.) hydraulic control valve
- 5° forward / 6° backward tilt.

HYSTER-YALE UK LIMITED

trading as **Yale Europe Materials Handling**
Centennial House, Frimley Business Park,
Frimley, Surrey GU16 7SG, United Kingdom.

Tel: +44 (0) 1276 538500



Fax: +44 (0) 1276 538559

www.yale-forklifts.eu



Publication part no. 220990347 Rev.09 Printed in The Netherlands (1118HG) EN.

Safety: This truck conforms to the current EU requirements. Specification is subject to change without notice.

Yale, VERACITOR and  are registered trademarks. "PEOPLE, PRODUCTS, PRODUCTIVITY", PREMIER, Hi-Vis, and CSS are trademarks in the United States and certain other jurisdictions. MATERIALS HANDLING CENTRAL and MATERIAL HANDLING CENTRAL are Service Marks in the United States and certain other jurisdictions.  is a Registered Copyright.

©Yale Europe Materials Handling 2018. All rights reserved. Truck shown with optional equipment.
Country of Registration: England and Wales. Company Registration Number: 02636775